



Servo Motors

Unimotor hd, Unimotor fm, NT Series and XV Series

0.9 - 752 lb-in (0.1 - 85.0 Nm)
230 V | 460 V



Control Techniques™

EMERSON™
Industrial Automation

Contents

Introduction: A Servo Motor for Every Application	1		
Selecting the Right Motor for the Right Drive	3		
Electronic Nameplates.....	3		
UNIMOTOR FM 230 V 460 V			
Flexible Configuration AC Servo Motors	4		
75 mm Frame Ratings	6		
75 mm Frame Dimensions	7		
95 mm Frame Ratings	8		
95 mm Frame Dimensions	9		
115 mm Frame Ratings	10		
115 mm Frame Dimensions	11		
142 mm Frame Ratings	12		
142 mm Frame Dimensions	13		
190 mm Frame Ratings – 230 V	14		
190 mm Frame Ratings – 460 V	15		
190 mm Frame Dimensions – 230 V and 460 V	16		
250 mm Frame Ratings	17		
250 mm Frame Dimensions	18		
Selection Considerations	19		
UNIMOTOR HD 230 V 460 V			
Compact, Powerful High Dynamic AC Servo Motors	21		
Order Information	22		
55 mm Frame Ratings and Dimensions	23		
67 mm Frame Ratings and Dimensions	24		
89 mm Frame Ratings and Dimensions	25		
115 mm Frame Ratings and Dimensions	26		
142 mm Frame Ratings and Dimensions	27		
190 mm Frame Ratings and Dimensions	28		
Selection Considerations	29		
		NT MOTOR 230 V	
		Compact NEMA or Metric Flange AC Servo Motors	31
		2-inch Frame Ratings and Dimensions	32
		3-inch Frame Ratings and Dimensions	33
		Flying Lead and Connector Details	34
		Flying Lead and Connector Details	35
		Selection Considerations	36
		XV MOTOR 230 V	
		Economical Metric AC Servo Motor	37
		40 mm Frame Ratings and Dimensions	38
		60/80 mm Frame Ratings and Dimensions	39
		130 mm Frame Ratings and Dimensions	40
		Selection Considerations	41
		CABLES	
		Unimotor hd, Unimotor fm	43
		Unimotor hd, Unimotor fm, NT (-ExNS)	44
		Unimotor hd, Unimotor fm, NT (-ExNS)	45
		Unimotor hd, Unimotor fm	46
		NT Motors to Drives	49
		XV Motors to Drives	51
		FAN KITS	
		Fan Kits	52

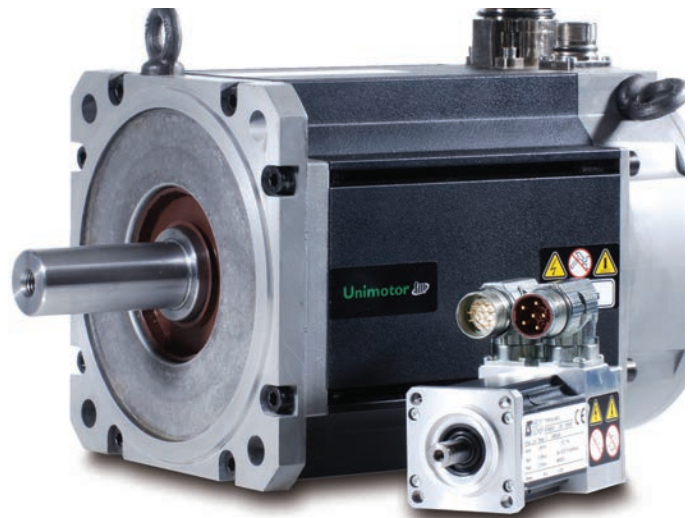

RoHS
Compliant



A Servo Motor for Every Application

Reliability and Innovation

Emerson Industrial Automation designs its Control Techniques products using a proven development process that prioritizes innovation and reliability. This process has resulted in Emerson's market-leading reputation for performance and quality.

Emerson Industrial Automation offers a wide range of reliable servo motors designed to meet specific application requirements. When matched to a Control Techniques' brand servo drive product (Unidrive M, Digitax ST, Epsilon EP or MDS Servo drive), the resulting drive/motor combination provides an optimized system in terms of ratings, performance, cost and ease of use.

Today, businesses of all sizes are searching for partners who understand the unique demands of today's global economy. Time and again they turn to Emerson Industrial Automation. With our world-class brands, broad industry experience and extensive global presence, Emerson Industrial Automation is uniquely positioned to deliver cost-effective solutions for the ever-changing industrial manufacturing market.

Performance Advantage

Unimotor fm

Designed for flexible configuration for use in a wide range of applications. A high inertia option is available.

- **Voltage Rating:** 230 V/460 V
- **Continuous Torque:** 10.6 to 1204 lb-in (1.2 to 136 Nm)
- **Multiple Feedback Choices:** Resolver, incremental and absolute encoder with multiple connector options
- **Frame Sizes (with NEMA flange options):** 75, 95, 115, 142, 190 and 250 mm
- **Ratings:** IP65; UL, CE and RoHS

Unimotor hd

Compact low-inertia servo motor for high-dynamic applications

- **Voltage Rating:** 230 V/460 V
- **Continuous Torque:** 6.4 to 752 lb-in (0.72 to 85.0 Nm)
- **Multiple Feedback Choices:** Resolver, encoder and absolute encoder
- **Frame Sizes:** 55, 67, 89, 115, 142 and 190 mm
- **Ratings:** IP65; UL, CE and RoHS

NT Motor

Compact NEMA or metric flange motors

- **Voltage Rating:** 230 V
- **Continuous Torque:** 7.5 to 56 lb-in (0.85 to 6.3 Nm)
- **Multiple Feedback Choices:** Incremental encoder
- **Flying Lead Option**
- **Frame Sizes:** English (NEMA 23 or 34) or Metric (IEC-72-1)
- **Ratings:** IP65; UL and RoHS

XV Motor

Economical metric motors

- **Voltage Rating:** 230 V
- **Continuous Torque:** 0.9 to 101 lb-in (0.11 to 11.5 Nm)
- **Frame Sizes:** 40, 60, 80 and 130 mm
- **Ratings:** IP55 and IP65; UL, CE and RoHS

Shaft seals standard on Unimotor hd, Unimotor fm and NT Series motors

A Wide Range of Rugged and Reliable Servo Motors

Servo Motor	Unimotor fm	Unimotor hd	NT Series	XV Series
Product Matrix				
Motor Family	Page 4	Page 21	Page 31	Page 37
Drive Voltage	230 V / 460 V	230 V / 460 V	230 V	230 V
Continuous Stall Torque	Up to 1204 lb-in (136 Nm)	Up to 752 lb-in (85.0 Nm)	Up to 56 lb-in (6.3 Nm)	Up to 101 lb-in (11.4 Nm)
Flange	IEC (NEMA option)	IEC	IEC, NEMA	Metric
Frame	75, 95, 115, 142, 190, 250 mm	55, 67, 89, 115, 142, 190 mm	2, 3 in	40, 60, 80, 130 mm
Inertia	Med. (high inertia option)	Low	Low	Low, medium
Peak Torque	Up to 3611 lb-in (408 Nm)	Up to 2257 lb-in (255.0 Nm)	Up to 144 lb-in (16.2 Nm)	Up to 301 lb-in (34 Nm)
Base Speeds	Up to 6000 rpm	Up to 6000 rpm	Up to 5000 rpm	Up to 5000 rpm
Brake Options	24 Vdc Holding Brake			
Connector Options	Circular style frame-mounted 90° and rotatable; optional 90° fixed, vertical, or mixed	Circular style frame mounted 90° and rotatable	MS or circular style frame mounted, MS style on 40-in lead, flying leads, drive connector terminated leads (20 ft max.)	AMP Mat-n-Loc on 1-ft. lead (40 to 80 mm); MS style frame-mounted (130 mm)
Feedback Options	Incremental encoders, SinCos single- and multi-turn, SinCos single and multi-turn, resolver, HIPERFACE® and EnDat	Incremental encoders, SinCos single- and multi-turn, SinCos single and multi-turn, resolver, HIPERFACE® and EnDat	Incremental 2048 line count	Incremental 2048 line count
Ingress Protection	IP65	IP65	IP65, IP67, IP68	IP55, IP65
Approvals	CE, UL, RoHS	CE, UL, RoHS	UL, RoHS	CE, UL, RoHS
Shaft Seals	✓	✓	✓	

Why Motion Customers Choose Emerson's Motion Control Solutions...

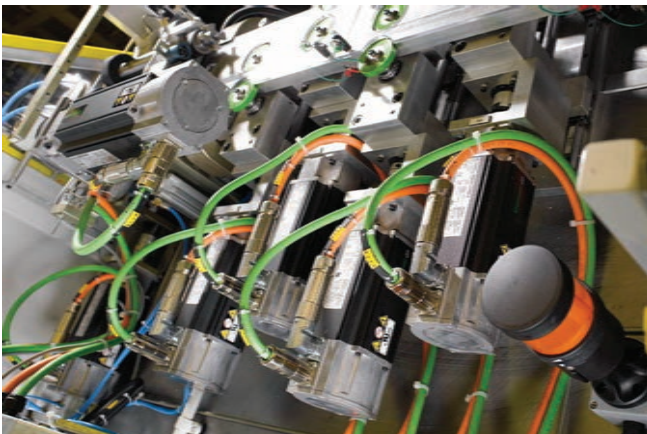

- A full line of servo motors up to 1200 lb-in
- Single-source motion control lowers total system costs
- FREE software offers the ultimate programming capability and greatly reduces programming time
- Multiple fieldbus options including EtherCAT, EtherNet I/P, Modbus TCP/IP and more
- High-speed, peer-to-peer communications
- 8 feedback types supported as standard
- Integrated programs eliminate need for PLC
- Drive and Automation Center support
- Zero-space internal EMI and dynamic braking resistor options
- AC drives with closed-loop vector control and sensorless rotor control

Selecting the Right Motor for the Right Drive

Emerson Industrial Automation drive-and-motor combinations provide an optimized system in terms of ratings, performance, cost and ease of use. You can manually select the system components using the following steps, or download the SERVOSoft® sizing software which includes our Control Techniques' brand of servo drive and motor data.

1. Determine the application's continuous and peak torque requirements at various motor shaft speeds, then refer to motor data tables and the visual reference overview to help determine which motor family will be most appropriate for the application.
2. Once the motor family is selected, use this brochure to select a specific motor model that delivers the required torque and speed. Make note of the continuous and peak current (Amps) requirements of the selected motor.
3. Check the specification tables in the Control Techniques' brand individual drive brochures for Digitax ST, Epsilon EP, Unidrive M or MDS servo drives to select the drive model that delivers adequate continuous and peak torque for the selected motor.
4. Refer to the Servo Motor Cables section of this brochure to select the motor power and feedback cables for the selected motor and drive.
5. Confirm that the ratio of rotor inertia to load inertia is <10:1

$$\text{load inertia/rotor inertia} < 10$$

Note: A gear reducer will reduce the load inertia based on the following equation:

$$\text{Reflected load inertia} = \text{load inertia}/\text{gear ratio}^2$$

Note: When specifying a motor system, be sure to consider such options as user-interfaces (HMI), braking resistors and other options and accessories that will enhance the system's performance and value.

Electronic Nameplates

Some motors fitted with high-resolution SinCos or absolute encoders are pre-loaded with the motor "electronic nameplate" data during the manufacturing process. This data can be read by most Control Techniques' brand servo drives and used to automatically optimize the drive settings. This feature simplifies commissioning and maintenance, ensures consistent performance and saves time.

Example

using the NT motor family and Digitax ST servo drive family

Step 1: The application requires 12 lb-in continuous torque.

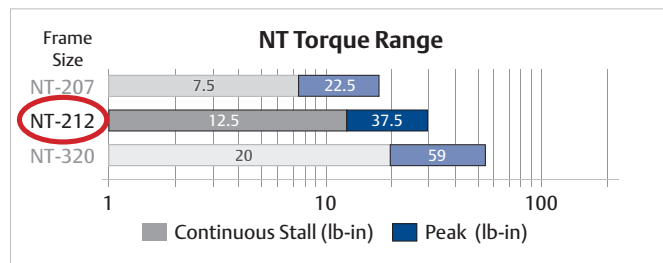

Step 2: The Servo Motors brochure lists the NT-212 motor with 2.7 A stall current.

Motor Frame Size (in)	2	230	
Voltage (Vrms)	230	230	
Model	NT-207	NT-212	
Continuous Stall Torque (lb-in)	7.5	12.5	
Continuous Stall Torque (Nm)	0.85	1.4	
Peak Torque (lb-in)	22.5	37.5	
Peak Torque (Nm)	2.54	4.24	
Inertia (lb-in-sec ²)	0.000094	0.000164	
Inertia (kgm ²)	0.0000106	0.0000185	
Motor Weight (lb)	3	4	
Motor Weight (kg)	1.36	1.81	
Maximum Cogging (lb-in)	0.094	0.12	
Maximum Cogging (Nm)	0.011	0.014	
5000 rpm	Kt (lb-in/A) =	5.12	5.08
	Kt (Nm/A) =	0.58	0.57
	Ke (V/k rpm) =	35	34.7
Rated Torque (lb-in)	7.50	12.50	
Rated Torque (Nm)	0.85	1.4	
Stall Current (A)	1.7	2.7	
Rated Power (kW)	0.432	0.740	
R (ph-ph) (Ohms)	11.1	4.56	
L (ph-ph) (mH)	39.1	18.9	

Step 3: Select the Digitax ST drive with adequate current rating.

Ratings — Digitax ST

Drive Model Number	Voltage / Ø	Output Current*	
		Cont. A	Peak A
DST1201	200-230 3Ø	1.7	5.1
DST1202	200-230 3Ø	3.8	11.4
DST1203	200-230 3Ø	5.4	16.2
DST1204	200-230 3Ø	7.6	22.8
DST1401	380-480 3Ø	1.5	4.5

Drive switching frequency at 6 kHz for rated performance

*Peak current is duty cycle limited

**Derate continuous current above 6 kHz drive switching frequency

For comprehensive information on Control Techniques' brand motor drive solutions, refer to our website the following brochures:
Unidrive M, Digitax ST, Epsilon EP, MDS

Unimotor fm 230 V / 460 V

UNIMOTOR FM

Flexible Configuration AC Servo Motors

Unimotor fm is a high performance, brushless AC Servo motor range matched for use with Control Techniques' brand drives. "FM" stands for "Flexible Motor" and is designed to accommodate a wide range of applications. The motors are available in six frame sizes with various mounting arrangements and motor lengths. Emerson drives and motors are designed to function as an optimized system. Unimotor fm is the perfect partner for Unidrive M, Digitax ST and Epsilon EP servo drives.

Key Features

- Torque range: 12.4 to 1204 lb-in (1.4 to 136.0 Nm)
- Medium inertia design with high inertia option available
- Connector styles include vertical, low profile and 90° rotatable
- Variety of flange possibilities (IEC/NEMA)
- Holding brake option
- IP65 conformance
- Winding to suit 230 V and 460 V
- Speed options include 2000, 3000, 4000 and 6000 rpm
- Multiple feedback options:
 - Resolver: Robust for extreme applications and conditions — lower accuracy, medium resolution
 - Incremental encoder: High accuracy, medium resolution
 - Absolute: Medium accuracy, medium resolution, single-turn and multi-turns
 - SinCos/Absolute: High accuracy, high resolution, single-turn and multi-turn
 - HIPERFACE (SICK) and EnDat (Heidenhain) protocols supported

Approvals



Unimotor

NOW WITH EVEN HIGHER PERFORMANCE!



Unimotor fm Torque Range

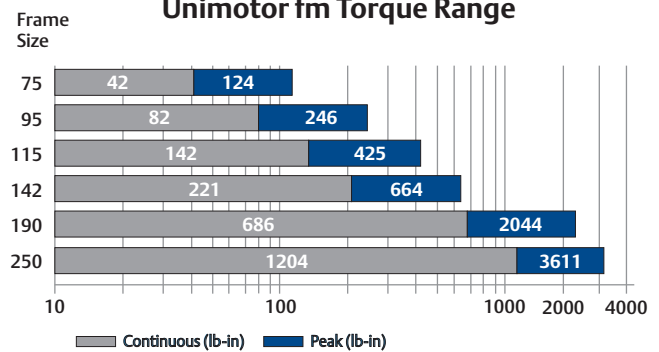

Electronic Nameplate Capability

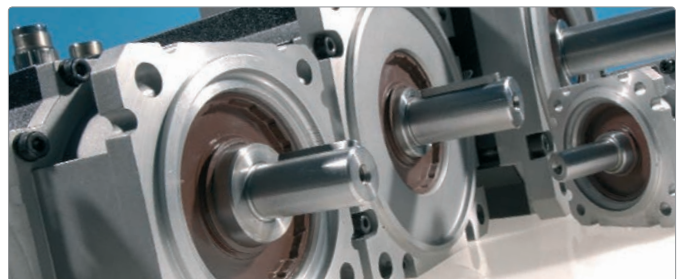

When a Unidrive M, Unidrive SP or Digitax ST servo drive is connected to a SinCos or absolute encoder, it can recognize and communicate with the motor to obtain the "electronic nameplate" data. This motor data can then be used to automatically optimize the drive settings. This feature simplifies commissioning and maintenance, ensures consistent performance and saves time.

Unimotor fm Order Information

Use the information below to create an order code for a Unimotor fm (top row is an example).

095	U3	A	30	5	B	A	CA	A	100	190
Frame size	Motor voltage	Stator length	Rated speed (rpm)	Brake	Connection type	Output shaft	Feedback device	Inertia	BCD	Shaft Diameter (ex. 110=11.0 mm)
075	E3 = 230 V	075 Frame	20 = 2000	0 = No Brake	075-142 Frames	075-250 Frames	075-142 Frames	075-250 Frames	075 Frame	Shaft Length (mm)
095	U3 = 460 V	B	30 = 3000	5 = 24 Vdc Parking brake	B = Power and signal 90° and rotatable size 1.0	A = Keyway w/ Full Key installed	AE = Resolver	A = Standard + PTC	Std	Frame Length
115		C	40 = 4000		C = Power 90° rotatable and signal vertical size 1.0	B = No Keyway	CA = Incremental Encoder (Std)	B = High + PTC	080 Opt	23
142	250 Frame	D	60 = 6000*		V = Power and signal vertical size 1.0	E* = Keyway w/ Half Key installed	EB = Optical Absolute Multi-turn EnDat	C = Standard + KTY84-130 thermistor	085 Opt	30
190	U3 = 460 V	095 -142 Frames	250 Frame			F* = Keyway w/ Half and Full Key included	FB = Optical Absolute Single turn EnDat	D = High + KTY84-130 thermistor	095 Frame	40
250		A	10 = 1000		142-190 Frames		EC = Inductive Absolute Multi-turn EnDat		100 Std	
		B	15 = 1500		J = 1.5 size Power 90° and signal 90° and rotatable		FC = Inductive Absolute Single turn EnDat		098 Opt	30
		C	20 = 2000		M = Power 90° rotatable and signal vertical size 1.5		RA = Optical SinCos Multi-turn HIPERFACE		115 Opt	40
		D	25 = 2500		N = Power and signal vertical size 1.5		SA = Optical SinCos Single turn HIPERFACE		115 Frame	50
		E			115-190 Frames				115 Std	
		190 Frame			H = Power hybrid box and signal vertical		AE = Resolver		130 Opt	40
		A			H = Power hybrid box and signal vertical		CA = Incremental Encoder (Std)		142 Frame	50
		B			250* Frame		EB = Optical Absolute Multi-turn EnDat		165 Std	50
		C			H = Power hybrid box and signal vertical (Std)		FB = Optical Absolute Single turn EnDat		149 Opt	
		D					RA = Optical SinCos Multi-turn HIPERFACE		190 Frame	50
		E					SA = Optical SinCos Single turn HIPERFACE		215 Std	58
		F							250 Frame	80*
		G							300 Std	58
		H							190 Frame	58
		250 Frame							250 Frame	58
		D							320*	80*
		E							320	58
		F							380	58
									480	110
										D-F

*Add (-SREL) to end of E3/U3 order string for 80 mm length shafts on 190 mm frames.

Notes:

*Half key is used to balance shaft. It does not complete shaft radius

a 6000 rpm not available on all frames sizes

190 – Lifting eyelets will be fitted on all 190 motors. This is to enable easy handling of these motors that are often over 55 lbs in weight. If there is an issue with the lifting eyes causing an obstruction when mounting the mating cables then the lifting eyelets may be removed once the motor is installed.

Hybrid Box Connection “H” – Due to the increased power ratings now available on the E3/U3 motors a hybrid box is now the standard power connection type on some 115 and 190 frames.

142 Power Connector Rating - Due to the increased power ratings now available of the E3/U3 motors power connector type “J” or “M” (Size 1.5 power connector) is now the standard on some 142 frames.

Unimotor fm 75 mm Frame Ratings

Motor Frame Size (mm)		075E3				075U3			
Voltage (Vrms)		230				460			
Frame Length		A	B	C	D	A	B	C	D
Continuous Stall Torque (lb-in)		12.4	23.9	32.7	41.6	12.4	23.9	32.7	41.6
Continuous Stall Torque (Nm)		1.4	2.7	3.7	4.7	1.4	2.7	3.7	4.7
Peak Torque (lb-in)		38	71	99	124	38	71	99	124
Peak Torque (Nm)		4.3	8	11.2	14	4.3	8	11.2	14
Standard Inertia (lb-in-sec ²)		0.00069	0.00108	0.00142	0.00180	0.00069	0.00108	0.00142	0.00180
Standard Inertia (kgm ²)		0.00008	0.00012	0.00016	0.00020	0.00008	0.00012	0.00016	0.00020
High Inertia (lb-in-sec ²)		0.00104	0.00142	0.00180	0.00218	0.00104	0.00142	0.00180	0.00218
High Inertia (kgm ²)		0.00012	0.00016	0.00020	0.00025	0.00012	0.00016	0.00020	0.00025
Winding Thermal Time Const. (s)		63	58	73	78	63	58	73	78
Motor Weight (lbs)		6.4	8.1	9.9	11.7	6.4	8.1	9.9	11.7
Motor Weight (kg)		2.9	3.7	4.5	5.3	2.9	3.7	4.5	5.3
Shaft Diameter (mm)		11	14	14	14	11	19	14	14
Shaft Length (mm)		23	30	30	30	23	30	30	30
2000 rpm	Kt (lb-in/A) =	12.4				21.24			
	Kt (Nm/A) =	1.4				2.4			
	Ke (V/k rpm) =	85.5				147			
Rated Torque (lb-in)		11.5	22.1	31.0	39.8	11.5	21.9	31.0	39.5
Rated Torque (Nm)		1.3	2.5	3.5	4.5	1.3	2.5	3.5	4.5
Stall Current (A)		1.0	1.9	2.7	3.3	0.6	1.1	1.6	1.9
Rated Power (kW)		0.72	0.52	0.73	0.93	0.27	0.52	0.73	0.93
R (ph-ph) (Ohms)		48.24	16.32	8.96	6.22	148.5	52.2	27.3	19.97
L (ph-ph) (mH)		87.47	39.77	24.68	19.15	258.7	117.28	74.2	56.97
3000 rpm	Kt (lb-in/A) =	8.23				14.16			
	Kt (Nm/A) =	0.93				1.6			
	Ke (V/k rpm) =	57.0				98.0			
Rated Torque (lb-in)		11.5	20.4	29.2	37.2	11.5	20.3	29.3	37.0
Rated Torque (Nm)		1.3	2.3	3.3	4.2	1.3	2.29	3.3	4.18
Stall Current (A)		1.55	2.85	4.9	5.02	0.90	1.66	2.33	2.92
Rated Power (kW)		0.41	0.72	1.04	1.31	0.41	0.72	1.04	1.31
R (ph-ph) (Ohms)		19.8	6.69	3.71	2.72	62.08	21.07	12.54	7.81
L (ph-ph) (mH)		37.2	16.8	10.69	8.27	114.6	52.65	34.18	23.89
4000 rpm	Kt (lb-in/A) =	6.37				10.62			
	Kt (Nm/A) =	0.72				1.2			
	Ke (V/k rpm) =	44.0				73.5			
Rated Torque (lb-in)		10.6	18.6	24.8	33.6	10.6	18.2	24.7	33.6
Rated Torque (Nm)		1.2	2.1	2.8	3.8	1.2	2.06	2.79	3.8
Stall Current (A)		2.06	3.79	5.31	6.67	1.20	2.21	3.10	3.89
Rated Power (kW)		0.5	0.86	1.17	1.59	0.50	0.86	1.17	1.59
R (ph-ph) (Ohms)		12.44	4.01	2.26	1.53	38.01	12.71	6.49	4.94
L (ph-ph) (mH)		23.35	9.62	6.32	4.63	68.39	30.46	18.28	13.97
6000 rpm	Kt (lb-in/A) =	4.16				7.08			
	Kt (Nm/A) =	0.47				0.8			
	Ke (V/k rpm) =	28.5				49.0			
Rated Torque (lb-in)		9.7	16.8	24.8	30.1	9.6	17.0	24.3	30.1
Rated Torque (Nm)		1.1	1.9	2.8	3.4	1.08	1.92	2.75	3.4
Stall Current (A)		3.06	5.64	7.91	9.94	1.80	3.31	4.65	5.84
Rated Power (kW)		0.68	1.21	1.73	2.14	0.68	1.21	1.73	2.14
R (ph-ph) (Ohms)		5.37	1.81	1.02	0.68	15.48	5.19	2.86	2.12
L (ph-ph) (mH)		9.8	4.42	2.88	2.06	28.66	12.77	8.01	6.33

NOTES:

- Δt = 212 °F (100 °C) winding 104 °F (40 °C) maximum ambient
- All data subject to ±10% tolerance
- Stall torque, rated torque and power relate to maximum continuous operation tested in a 68 °F (20 °C) ambient at 12 kHz drive switching frequency
- Emerson has an ongoing process of development and reserves the right to change the specification without notice
- All other figures relate to a 68 °F (20 °C) motor temperature; maximum intermittent winding temperature is 284 °F (140 °C)

Unimotor fm 75 mm Frame Dimensions

NOTE: Output key dimensions (E,F,G and H) are applicable to keyed units only. 90° connectors are standard

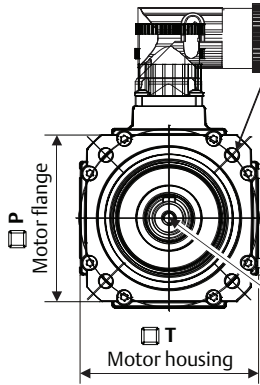
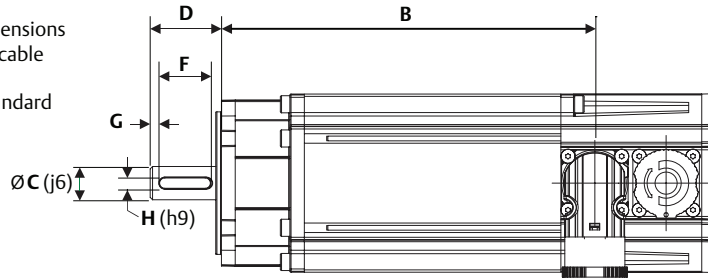

4 holes ØR (H14) equispaced on a mounting BCD ØS

Tapped hole thread size I to depth J

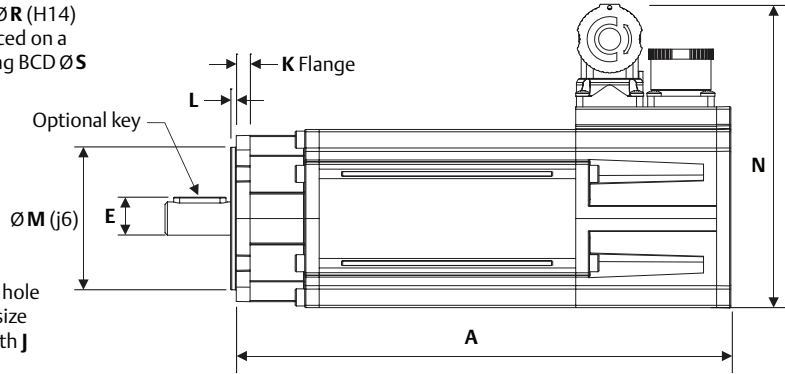

For vertical connectors, allow approximately 175.0mm clearance for mating cable

Motor Dimensions*	Frame Length								
	A		B		C		D		
	(in)	(mm)	(in)	(mm)	(in)	(mm)	(in)	(mm)	
Unbraked Length	A	8.20	208.2	9.38	238.2	10.56	268.2	11.74	298.2
	B	6.19	157.2	7.37	187.2	8.55	217.2	9.73	247.2
Braked Length	A	9.38	238.2	10.56	268.2	11.74	298.2	12.92	328.2
	B	7.37	187.2	8.55	217.2	9.73	247.2	10.91	277.2

*PCD 085 motor lengths differ from the above, refer to drawings for complete details

Connector Type	Connector Height		
	(in)	(mm)	
"A"	N	4.7	118.5
"B" (std)		5.0	126.0
"C"		5.0	126.0
"V"		4.7	118.5

Dimensions for power connectors size 1.0

Flange Dimensions		BCD Code					
		Standard		Optional			
		075		080		085	
		(in)	(mm)	(in)	(mm)	(in)	(mm)
Flange Thickness	K	0.23	5.8	0.23	5.8	0.23	5.8
Pilot Thickness	L	0.09	2.4	0.09	2.4	0.09	2.4
Pilot Diameter (j6)	M	2.36	60.0	2.36	60.0	2.76	70.0
Flange Square	P	2.76	70.0	2.76	70.0	3.15	80.0
Mounting Hole Diameter (H14)	R	0.23	5.8	0.23	5.8	0.28	7.0
Mounting Hole BCD	S	2.6 to 3.0	66.7 to 75.0	3.0 to 3.2	75.0 to 80.0	3.4	85
Motor Housing	T	2.95	75	2.95	75	2.95	75
Mounting Bolts		M5				M6	

Shaft Dimensions		Shaft Diameter Code					
		11.0 mm Frame A		14.0 mm Frames B-D		19.0 mm Opt	
		(in)	(mm)	(in)	(mm)	(in)	(mm)
Shaft Diameter (j6)	C	0.43	11.0	0.55	14.0	0.75	19.0
Shaft Length	D ¹	0.91	23.0	1.18	30.0	1.57	40.0
Key Height	E ²	0.49	12.5	0.63	16.0	0.85	21.5
Key Length	F ³	0.55	14.0	0.98	25.0	1.26	32.0
Key-to-Shaft End	G ⁴	0.14	3.6	0.06	1.5	0.14	3.6
Key Width (H9)	H	0.16	4.0	0.20	5.0	0.24	6.0
Tapped Hole Thread Size	I	M4 x 0.7		M5 x 0.8		M6 x 1.0	
Tapped Hole Depth	J ⁵	0.43	11.0	0.53	13.5	0.67	17.0

¹±0.45 mm, ²To IEC 72-1, ³±0.25 mm, ⁴±1.1 mm, ⁵±0.4 mm

Unimotor fm 95 mm Frame Ratings

Motor Frame Size (mm)		095E3					095U3				
Voltage (Vrms)		230					460				
Frame Length		A	B	C	D	E	A	B	C	D	E
Continuous Stall Torque (lb-in)		22.1	39.8	55.8	69.9	82.3	21.7	39.8	55.8	69.9	81.9
Continuous Stall Torque (Nm)		2.5	4.5	6.3	7.9	9.3	2.5	4.5	6.3	7.9	9.3
Peak Torque (lb-in)		65	119	167	210	246	65	119	167	210	246
Peak Torque (Nm)		7.4	13.5	18.9	23.7	27.8	7.4	13.5	18.9	23.7	27.8
Standard Inertia (lb-in-sec ²)		0.00128	0.00230	0.00329	0.00427	0.00531	0.00128	0.00230	0.00329	0.00427	0.00531
Standard Inertia (kgm ²)		0.00015	0.00026	0.00037	0.00048	0.00060	0.00015	0.00026	0.00037	0.00048	0.00060
High Inertia Option (lb-in-sec ²)		0.00116	0.00398	0.00496	0.00593	0.00690	0.00116	0.00398	0.00496	0.00593	0.00690
High Inertia Option (kgm ²)		0.00013	0.00045	0.00056	0.00067	0.00078	0.00013	0.00045	0.00056	0.00067	0.00078
Winding Thermal Time Const. (s)		84	82	73	90	108	84	82	90	108	112
Motor Weight (lbs)		10.1	12.8	15.4	18	20.7	10.1	12.8	15.4	18	20.7
Motor Weight (kg)		4.6	5.8	7	8.2	9.4	4.6	5.8	7	8.2	9.4
Shaft Diameter (mm)		14	19	19	19	19	14	19	19	19	19
Shaft Length (mm)		30	40	40	40	40	30	40	40	40	40
2000 rpm	Kt (lb-in/A) =	12.4					21.2				
	Kt (Nm/A) =	1.4					2.4				
	Ke (V/k rpm) =	85.5					147.0				
Rated Torque (lb-in)		21.2	38.1	52.2	64.6	75.2	21.2	38.1	52.2	64.6	75.2
Rated Torque (Nm)		2.4	4.3	5.9	7.3	8.5	2.4	4.3	5.9	7.3	8.5
Stall Current (A)		1.8	3.2	4.5	5.6	6.6	1.0	1.9	2.6	3.3	3.9
Rated Power (kW)		0.51	0.9	1.23	1.53	1.77	0.51	0.9	1.23	1.53	1.77
R (ph-ph) (Ohms)		20.69	6.78	3.79	2.42	1.92	64.08	20.88	10.46	7.46	5.09
L (ph-ph) (mH)		57.78	26.1	16.36	11.83	9.75	173.4	78.16	47.02	35.44	27.18
3000 rpm	Kt (lb-in/A) =	8.23					14.2				
	Kt (Nm/A) =	0.93					1.60				
	Ke (V/k rpm) =	57.0					98.0				
Rated Torque (lb-in)		20.6	36.3	49.6	61.1	72.1	20.4	36.3	49.6	61.1	72.6
Rated Torque (Nm)		2.33	4.1	5.6	6.9	8.15	2.3	4.1	5.6	6.9	8.2
Stall Current (A)		2.63	4.84	6.77	8.49	9.95	1.5	2.8	3.9	4.9	5.8
Rated Power (kW)		0.73	1.29	1.76	2.17	2.56	0.73	1.29	1.76	2.17	2.56
R (ph-ph) (Ohms)		9.62	2.99	1.64	1.07	0.86	26.7	8.63	4.67	3.16	2.27
L (ph-ph) (mH)		26.29	11.47	7.15	5.16	4.35	76.65	33.71	21.09	15.95	12.06
4000 rpm	Kt (lb-in/A) =	6.2					10.6				
	Kt (Nm/A) =	0.72					1.2				
	Ke (V/k rpm) =	42.75					73.5				
Rated Torque (lb-in)		20.4	33.6	46.9	56.6	65.5	20.4	33.6	46.9	56.6	65.5
Rated Torque (Nm)		2.3	3.8	5.3	6.4	7.4	2.3	3.8	5.3	6.4	7.4
Stall Current (A)		3.5	6.43	9.0	11.29	13.21	2.0	3.8	5.3	6.6	7.7
Rated Power (kW)		0.94	1.59	2.2	2.68	3.1	0.94	1.59	2.2	2.68	3.1
R (ph-ph) (Ohms)		5.26	1.76	1.04	0.74	0.48	16.14	5.22	2.61	1.81	1.4
L (ph-ph) (mH)		14.94	6.67	4.52	3.53	2.44	44.25	19.54	11.75	8.86	7.25
6000 rpm	Kt (lb-in/A) =	4.2					7.1				
	Kt (Nm/A) =	0.47					0.8				
	Ke (V/k rpm) =	28.5					49.0				
Rated Torque (lb-in)		17.5	28.3	37.2			17.7	28.3	37.2		
Rated Torque (Nm)		1.98	3.2	4.2			2.0	3.2	4.2		
Stall Current (A)		5.21	9.57	13.4			3.1	5.6	7.9		
Rated Power (kW)		1.24	2.01	2.64			1.24	2.01	2.64		
R (ph-ph) (Ohms)		2.33	0.73	0.46			6.59	2.13	1.22		
L (ph-ph) (mH)		6.57	2.77	2.07			18.62	8.24	5.44		

NOTES:

- Δt = 212 °F (100 °C) winding 104 °F (40 °C) maximum ambient
- All data subject to ±10% tolerance
- Stall torque, rated torque and power relate to maximum continuous operation tested in a 68 °F (20 °C) ambient at 12 kHz drive switching frequency
- Emerson has an ongoing process of development and reserves the right to change the specification without notice
- All other figures relate to a 68 °F (20 °C) motor temperature; maximum intermittent winding temperature is 284 °F (140 °C)

Unimotor fm 95 mm Frame Dimensions

NOTE: Output key dimensions (E, F, G and H) are applicable to keyed units only. 90° connectors are standard

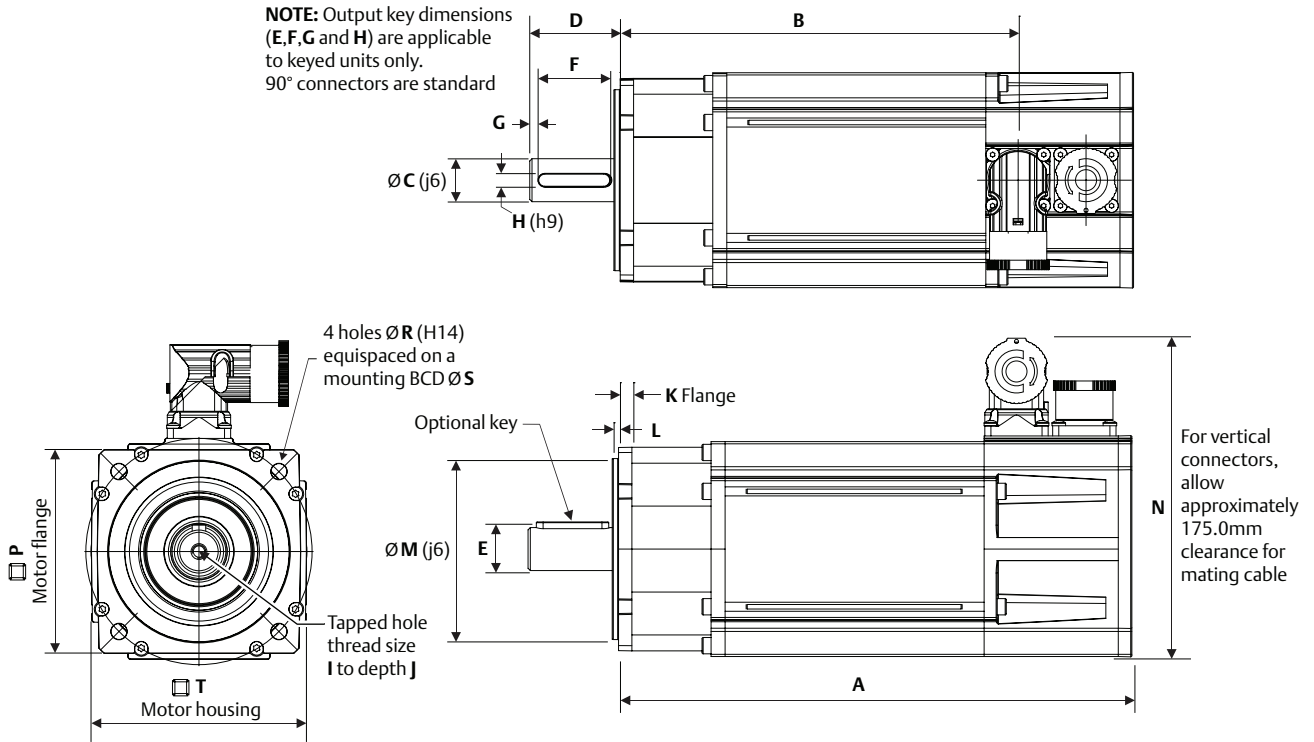

Motor Dimensions	Frame Length										
	A		B		C		D		E		
	(in)	(mm)	(in)	(mm)	(in)	(mm)	(in)	(mm)	(in)	(mm)	
Unbraked Length	A	8.93	226.9	10.11	256.9	11.3	286.9	12.48	316.9	13.66	346.9
	B	6.93	175.9	8.11	205.9	9.29	235.9	10.47	265.9	11.65	295.9
Braked Length	A	10.11	256.9	11.3	286.9	12.48	316.9	13.66	346.9	14.84	376.9
	B	8.11	205.9	9.29	235.9	10.47	265.9	11.65	295.9	12.83	325.9

BCD 098 and 115 mm motor lengths differ from the above, refer to draw for motor details

Connector Type	Connector Height		
	(in)	(mm)	
"A"	N	5.18	131.5
"B" (std)		5.47	139.0
"C"		5.47	139.0
"V"		5.18	131.5

Dimensions for power connectors size 1.0

Flange Dimensions		BCD Code					
		Standard		Optional			
		100		098		115	
		(in)	(mm)	(in)	(mm)	(in)	(mm)
Flange Thickness	K	0.23	5.9	0.268	6.8	0.268	6.8
Pilot Thickness	L	0.11	2.8	0.11	2.8	0.11	2.8
Pilot Diameter (j6)	M	3.15	80.0	2.87	73.0	3.74	95.0
Flange Square	P	3.54	90.0	3.54	90.0	4.13	105.0
Mounting Hole Dia. (H14)	R	0.28	7.0	0.28	7.0	0.29	10.0
Mounting Hole BCD	S	3.94	100.0	3.88	98.43	4.53	115.0
Motor Housing	T	3.74	95.0	3.74	95.0	3.74	95.0
Mounting Bolts		M6		M6		M8	

¹NEMA 34 flange option; shaft diameters differ from typical NEMA 34 flange

Shaft Dimensions		Shaft Diameter Code					
		14.0 mm Frame A		19.0 mm Frames B-E		22.0 mm Opt	
		(in)	(mm)	(in)	(mm)	(in)	(mm)
Shaft Diameter (j6)	C	0.55	14.0	0.75	19.0	0.866	22.0
Shaft Length	D ¹	1.18	30.0	1.57	40.0	1.97	50.0
Key Height	E ²	0.63	16.0	0.85	21.5	1.0	24.5
Key Length	F ³	0.98	25.0	1.26	32.0	1.63	40.0
Key-to-Shaft End	G ⁴	0.06	1.5	0.14	3.6	0.188	4.6
Key Width (H9)	H	0.20	5.0	0.24	6.0	0.245	6.0
Tapped Hole thread Size	I	M5 x 0.8		M6 x 1.0		M8 x 1.25	
Tapped Hole Depth	J ⁵	0.53	13.5	0.67	17.0	0.816	20.0

¹±0.45 mm, ²To IEC 72-1, ³±0.25 mm, ⁴±1.1 mm, ⁵±0.4 mm

Unimotor fm 115 mm Frame Ratings

Motor Frame Size (mm)	115E3					115U3					
Voltage (Vrms)	230					460					
Frame Length	A	B	C	D*	E*	A	B	C	D	E	
Continuous Stall Torque (lb-in)	35	65	96	121	142	35	65	96	121	142	
Continuous Stall Torque (Nm)	3.9	7.4	10.8	13.7	16.0	3.9	7.4	10.8	13.7	16.0	
Peak Torque (lb-in)	104	196	287	363	425	104	196	287	363	425	
Peak Torque (Nm)	11.7	22.2	32.4	41	48	11.7	22.2	32.4	41	48	
Standard Inertia (lb-in-sec ²)	0.00478	0.00682	0.00885	0.01106	0.0131	0.00478	0.00682	0.00885	0.01106	0.0131	
Standard Inertia (kgm ²)	0.00054	0.00077	0.001	0.00125	0.00148	0.00054	0.00077	0.001	0.00125	0.00148	
High Inertia Option (lb-in-sec ²)	0.00885	0.01089	0.01301	0.01513	0.01717	0.00885	0.01089	0.01301	0.01513	0.01717	
High Inertia Option (kgm ²)	0.001	0.00123	0.00147	0.00171	0.00194	0.001	0.00123	0.00147	0.00171	0.00194	
Winding Thermal Time Const. (s)	103	109	116	127	141	103	109	116	127	141	
Motor Weight (lbs)	15.2	19.4	23.5	27.7	31.9	15.2	19.4	23.5	27.7	31.9	
Motor Weight (kg)	6.9	8.8	10.7	12.6	14.5	6.9	8.8	10.7	12.6	14.5	
Shaft Diameter (mm)	19	19	19	24	24	19	19	19	24	24	
Shaft Length (mm)	40	40	40	50	50	40	40	40	50	50	
2000 rpm	Kt (lb-in/A) =		12.4			21.2					
	Kt (Nm/A) =		1.4			2.4					
	Ke (V/k rpm) =		85.5			147.0					
	Rated Torque (lb-in)	32.7	64.6	89.4	105.3	124.8	32.7	64.6	89.4	105.3	124.8
	Rated Torque (Nm)	3.7	7.3	10.1	11.9	14.1	3.7	7.3	10.1	11.9	14.1
	Stall Current (A)	2.8	5.3	7.7	9.8	11.4	1.6	3.1	4.5	5.7	6.7
	Rated Power (kW)	0.77	1.53	2.12	2.49	2.95	0.77	1.53	2.12	2.49	2.95
	R (ph-ph) (Ohms)	10.65	3.43	1.82	1.81	1.34	32.92	10.68	5.25	3.7	2.75
	L (ph-ph) (mH)	55.83	19.43	12.31	9.5	7.68	139.43	59.51	35.9	27.63	21.87
3000 rpm	Kt (lb-in/A) =		8.23			14.2					
	Kt (Nm/A) =		0.93			1.6					
	Ke (V/k rpm) =		57.00			98.0					
	Rated Torque (lb-in)	31.0	59.3	84.1	99.1	112.4*	31.0	59.3	84.1	99.1	112.4
	Rated Torque (Nm)	3.5	6.7	9.5	11.2	12.7	3.5	6.7	9.5	11.2	12.7
	Stall Current (A)	4.19	7.96	11.61	14.68	17.2	2.4	4.6	6.8	8.5	10.0
	Rated Power (kW)	1.1	2.1	2.98	3.52	3.99	1.1	2.1	2.98	3.52	3.99
	R (ph-ph) (Ohms)	4.91	1.52	0.81	0.57	0.43	14.74	4.37	2.3	1.53	1.23
	L (ph-ph) (mH)	20.26	8.63	5.47	4.35	3.41	57.29	25.19	15.57	11.6	9.89
4000 rpm	Kt (lb-in/A) =		6.2			10.6					
	Kt (Nm/A) =		0.7			1.2					
	Ke (V/k rpm) =		42.75			73.5					
	Rated Torque (lb-in)	26.6	51.3	66.4	73.5*	77.9*	26.6	51.3	66.4	73.5	77.9
	Rated Torque (Nm)	3.0	5.8	7.5	8.3	8.8	3.0	5.8	7.5	8.3	8.8
	Stall Current (A)	5.57	10.57	15.43	19.5	22.9	3.3	6.2	9.0	11.4	13.3
	Rated Power (kW)	1.26	2.43	3.12	3.46	3.69	1.26	2.43	3.12	3.46	3.69
	R (ph-ph) (Ohms)	3.05	0.93	0.49	0.3	0.27	8.49	2.61	1.31	0.84	0.66
	L (ph-ph) (mH)	12.44	5.13	3.34	2.25	2.18	33.79	14.87	8.98	6.27	5.35
6000 rpm	Kt (lb-in/A) =		4.2			7.1					
	Kt (Nm/A) =		0.47			0.8					
	Ke (V/k rpm) =		28.5			49.0					
	Rated Torque (lb-in)	23.9	44.3				23.9	44.3			
	Rated Torque (Nm)	2.7	5.0				2.7	5.0			
	Stall Current (A)	8.3	15.74				4.9	9.3			
	Rated Power (kW)	1.7	3.14				1.7	3.14			
	R (ph-ph) (Ohms)	1.5	0.41				3.48	1.09			
	L (ph-ph) (mH)	6.08	2.34				14.31	6.3			

NOTES:

- * Ratings shown require connector option "H" terminal box.
- Δt = 212 °F (100 °C) winding 104 °F (40 °C) maximum ambient
- All data subject to ±10% tolerance
- Stall torque, rated torque and power relate to maximum continuous operation tested in a 68 °F (20 °C) ambient at 12 kHz drive switching frequency
- Emerson has an ongoing process of development and reserves the right to change the specification without notice
- All other figures relate to a 68 °F (20 °C) motor temperature; maximum intermittent winding temperature is 284 °F (140 °C)

Unimotor fm 115 mm Frame Dimensions

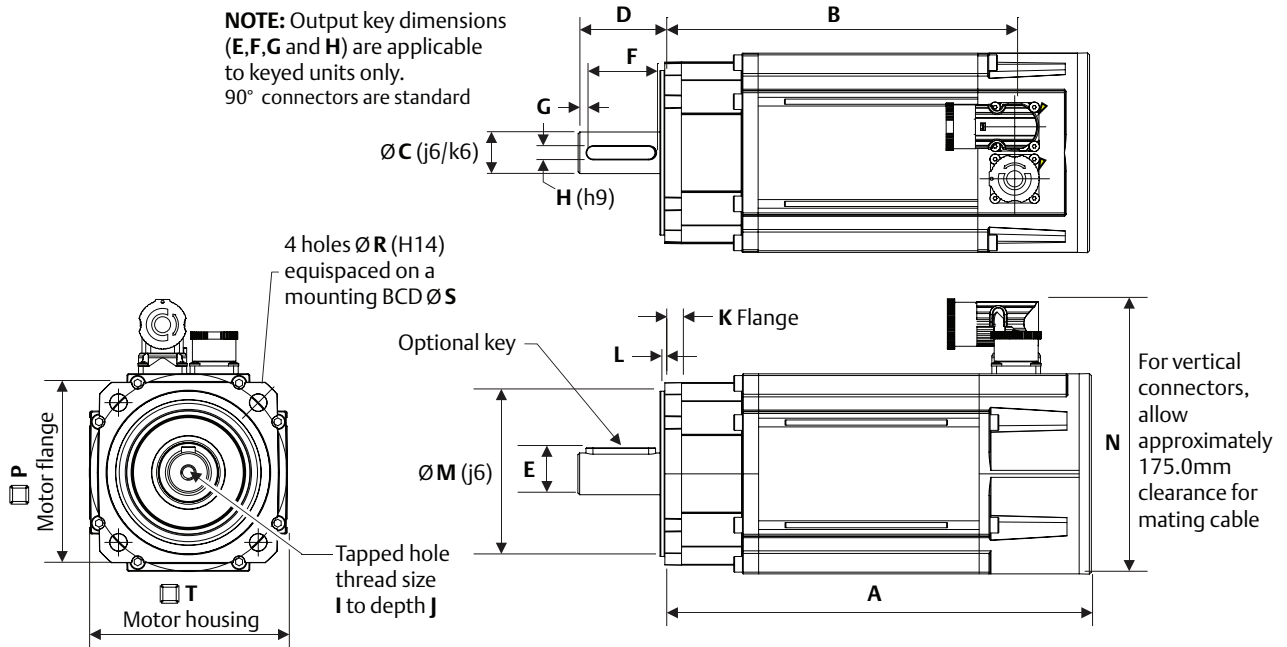

Motor Dimensions	Frame Length										
	A		B		C		D		E		
	(in)	(mm)	(in)	(mm)	(in)	(mm)	(in)	(mm)	(in)	(mm)	
Unbraked Length	A	9.71	246.6	10.89	276.6	12.07	306.6	13.25	336.6	14.43	366.6
	B	7.63	193.8	8.81	223.8	9.99	253.8	11.17	283.8	12.35	313.8
Braked Length	A	10.89	276.6	12.07	306.6	13.25	336.6	14.43	366.6	15.61	396.6
	B	8.81	223.8	9.99	253.8	11.17	283.8	12.35	313.8	13.54	343.8

BCD 130 motor lengths differ from the above, refer to draw for motor details

Connector Type	Connector Size	Connector Height	
		(in)	(mm)
"A"	N	1.0	5.87
"B" (std)		1.0	6.16
"C"		1.0	6.16
"V"		1.0	5.87
"J"		1.5	7.38
"M"		1.5	6.59

Flange Dimensions		BCD Code			
		Standard		Optional	
		115		130	
		(in)	(mm)	(in)	(mm)
Flange Thickness	K	0.39	10.1	0.52	13.2
Pilot Thickness	L	0.11	2.8	0.11	2.8
Pilot Diameter (J6)	M	3.74	95	4.33	110
Flange Square	P	4.13	105	5.12	130
Mounting Hole Dia. (H14)	R	0.39	10	0.39	10
Mounting Hole BCD	S	4.53	115	5.12	130
Motor Housing	T	4.53	115	4.53	115
Mounting Bolts		M8			

Shaft Dimensions		Shaft Diameter Code			
		19.0 mm Frame A-C		24.0 mm Frame D-E	
		(in)	(mm)	(in)	(mm)
Shaft Diameter (J6)	C	0.75	19.0	0.94	24.0
Shaft Length	D ¹	1.57	40.0	1.97	50.0
Key Height	E ²	0.85	21.5	1.06	27.0
Key Length	F ³	1.26	32.0	1.57	40.0
Key-to-Shaft End	G ⁴	0.14	3.6	0.18	4.6
Key Width (H9)	H	0.24	6.0	0.31	8.0
Tapped Hole thread Size	I	M6 x 1.0		M8 x 1.25	
Tapped Hole Depth	J ⁵	0.67	17.0	0.79	20.0

¹±0.45 mm, ²To IEC 72-1, ³±0.25 mm, ⁴±1.1 mm, ⁵±0.4 mm

Unimotor fm 142 mm Frame Ratings

Motor Frame Size (mm)	142E3					142U3					
Voltage (Vrms)	230					460					
Frame Length	A	B	C*	D*	E*	A	B	C	D	E*	
Continuous Stall Torque (lb-in)	55.0	97.0	139.0	181.0	221.0	55.0	97.0	139.0	181.0	221.0	
Continuous Stall Torque (Nm)	6.2	11.0	15.7	20.5	25.0	6.2	11.0	15.7	20.5	25.0	
Peak Torque (lb-in)	165.0	292.0	417.0	544.0	664.0	165.0	292.0	417.0	544.0	664.0	
Peak Torque (Nm)	18.6	33.0	47.1	61.5	75.0	18.6	33.0	47.1	61.5	75.0	
Standard Inertia (lb-in-sec ²)	0.00903	0.01496	0.0208	0.02673	0.03266	0.00903	0.01496	0.0208	0.02673	0.03266	
Standard Inertia (kgm ²)	0.00102	0.00169	0.00235	0.00302	0.00369	0.00102	0.00169	0.00235	0.00302	0.00369	
High Inertia Option (lb-in-sec ²)	0.02053	0.02638	0.03231	0.03815	0.04408	0.02053	0.02638	0.03231	0.03815	0.04408	
High Inertia Option (kgm ²)	0.00232	0.00298	0.00365	0.00431	0.00498	0.00232	0.00298	0.00365	0.00431	0.00498	
Winding Thermal Time Const. (s)	145	148	188	206	249	145	148	188	206	249	
Motor Weight (lbs)	18.3	25.1	31.9	38.7	45.5	18.3	25.1	31.9	38.7	45.5	
Motor Weight (kg)	8.3	11.4	14.5	17.6	20.7	8.3	11.4	14.5	17.6	20.7	
Shaft Diameter (mm)	24	24	24	24	24	24	24	24	24	24	
Shaft Length (mm)	50	50	50	50	50	50	50	50	50	50	
2000 rpm	Kt (lb-in/A) =					12.4					
	Kt (Nm/A) =					1.4					
	Ke (V/k rpm) =					85.5					
3000 rpm	Rated Torque (lb-in)	52.2	92.0	130.1	163.7	190.3*	52.2	92.0	130.1	163.7	190.3
	Rated Torque (Nm)	5.9	10.4	14.7	18.5	21.5	5.9	10.4	14.7	18.5	21.5
	Stall Current (A)	4.4	7.9	11.2	14.6	17.9	2.6	4.6	6.5	8.5	10.4
	Rated Power (kW)	1.23	2.18	3.08	3.87	4.49	1.23	2.18	3.08	3.87	4.49
	R (ph-ph) (Ohms)	5.56	1.54	0.80	0.51	0.40	14.64	4.71	2.38	1.60	1.11
	L (ph-ph) (mH)	35.43	14.25	8.99	6.35	5.25	98.76	42.15	26.32	19.46	15.08
	Kt (lb-in/A) =					8.23					
	Kt (Nm/A) =					0.93					
	Ke (V/k rpm) =					57.0					
	Rated Torque (lb-in)	48.7	84.1	113.3	141.6*	161.1*	48.7	84.1	113.3	141.6	161.1
Rated Torque (Nm)	5.5	9.5	12.8	16.0	18.2	5.5	9.5	12.8	16.0	18.2	
Stall Current (A)	6.67	11.83	16.88	22.04	26.88	3.9	6.9	9.8	12.8	15.6	
Rated Power (kW)	1.73	2.98	4.02	5.03	5.70	1.73	2.98	4.02	5.03	5.7	
R (ph-ph) (Ohms)	2.25	0.68	0.35	0.23	0.16	6.2	2.12	1.08	0.70	0.50	
L (ph-ph) (mH)	14.68	6.33	3.89	3.66	2.23	42.97	19.11	12.06	8.91	6.7	
4000 rpm	Kt (lb-in/A) =					6.2					
	Kt (Nm/A) =					0.7					
	Ke (V/k rpm) =					42.75					
Rated Torque (lb-in)	36.3	71.7	90.3*	108.0*	123.9*	36.3	71.7	90.3	108*	123.9*	
Rated Torque (Nm)	4.1	8.1	10.2	12.2	14.0	4.1	8.1	10.2	12.2	14.0	
Stall Current (A)	8.86	15.71	22.43	29.3	35.7	5.2	9.2	13.1	17.1	20.8	
Rated Power (kW)	1.72	3.37	4.27	5.11	5.86	1.72	3.37	4.27	5.11	5.86	
R (ph-ph) (Ohms)	1.29	0.38	0.23	0.13	0.09	3.64	1.18	0.61	0.41	0.29	
L (ph-ph) (mH)	8.39	3.44	2.49	1.99	1.2	24.44	10.54	6.78	5.06	3.97	
6000 rpm	Kt (lb-in/A) =					0.7					
	Kt (Nm/A) =					0.08					
	Ke (V/k rpm) =					49.0					
	Rated Torque (lb-in)	28.3		46.0							
	Rated Torque (Nm)	3.2		5.2							
	Stall Current (A)	7.8		13.8							
	Rated Power (kW)	2.01		3.27							
	R (ph-ph) (Ohms)	1.63		0.53							
	L (ph-ph) (mH)	11.08		4.78							

NOTES:

- * Ratings shown require connector option "J", "M", "N" size 1.5 power connector.
- Δt = 212 °F (100 °C) winding 104 °F (40 °C) maximum ambient
- All data subject to ±10% tolerance
- Stall torque, rated torque and power relate to maximum continuous operation tested in a 68 °F (20 °C) ambient at 12 kHz drive switching frequency
- Emerson has an ongoing process of development and reserves the right to change the specification without notice
- All other figures relate to a 68 °F (20 °C) motor temperature; maximum intermittent winding temperature is 284 °F (140 °C)

Unimotor fm 142 mm Frame Dimensions

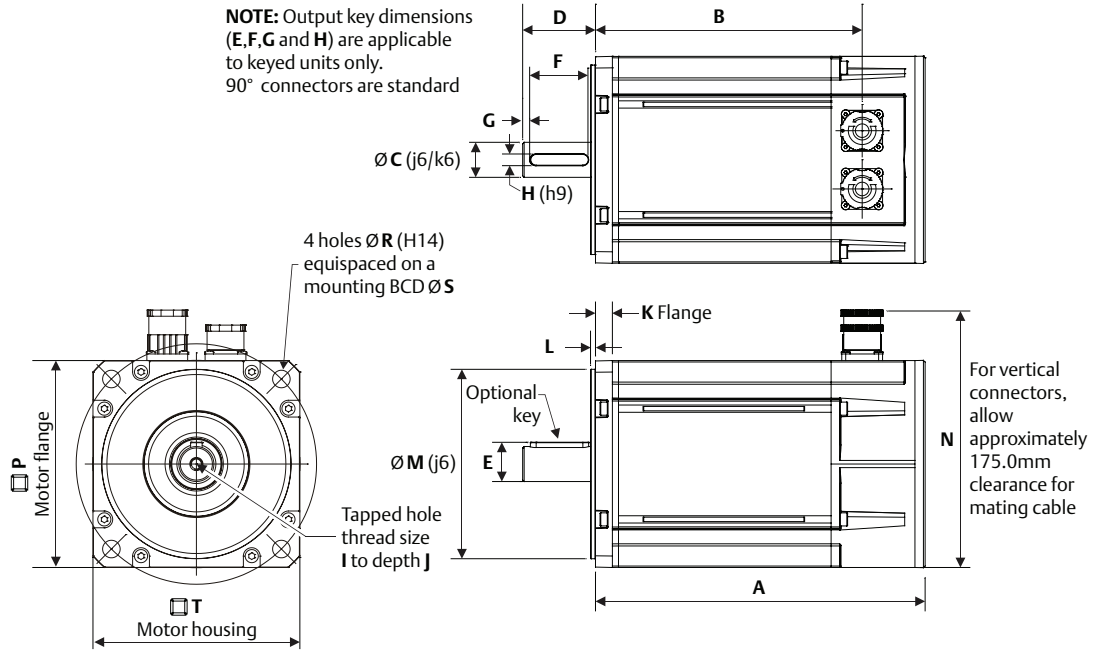

Motor Dimensions	Frame Length										
	A		B		C		D		E		
	(in)	(mm)	(in)	(mm)	(in)	(mm)	(in)	(mm)	(in)	(mm)	
Unbraked Length	A	7.59	192.8	8.77	222.8	9.95	252.8	11.13	282.8	12.31	312.8
	B	6.22	158	7.4	188	8.58	218	9.76	248	10.94	278
Braked Length	A	9.95	252.8	11.13	282.8	12.31	312.8	13.5	342.8	14.68	372.8
	B	8.58	218	9.76	248	10.94	278	12.13	308	13.31	338

BCD 149 motor lengths differ from the above, refer to draw for motor details

Connector Type	Connector Size	Connector Height	
		(in)	(mm)
"A"	N	1.0	6.93
"B" (std)		1.0	7.22
"C"		1.0	7.22
"V"		1.0	6.93
"J"		1.5	8.05
"M"		1.5	7.26

Flange Dimensions		BCD Code			
		Standard		Optional	
		165		149 ¹	
		(in)	(mm)	(in)	(mm)
Flange Thickness	K	0.55	14.0	0.45	11.5
Pilot Thickness	L	0.13	3.4	0.13	3.4
Pilot Diameter (j6)	M	5.12	130	4.5	114.3
Flange Square	P	5.59	142	5.51	140
Mounting Hole Dia. (H14)	R	0.47	12.0	0.47	12.0
Mounting Hole BCD	S	6.5	165	5.88	149.23
Motor Housing	T	5.59	142	5.59	142
Mounting Bolts		M10		M10	

¹NEMA 56 flange option; shaft diameter 0.945 in (24 mm)

Shaft Dimensions		Shaft Diameter Code			
		24.0 mm Frame A-C		32.0 mm Frame D-E	
		(in)	(mm)	(in)	(mm)
Shaft Diameter (j6)	C	0.94	24.0	1.26	32.0
Shaft Length	D ¹	1.97	50.0	2.28	58.0
Key Height	E ²	1.06	27.0	1.38	35.0
Key Length	F ³	1.57	40.0	1.97	50.0
Key-to-Shaft End	G ⁴	0.18	4.6	0.18	4.6
Key Width (H9)	H	0.31	8.0	0.39	10.0
Tapped Hole thread Size	I	M8 x 1.25		M12 x 1.75	
Tapped Hole Depth	J ⁵	0.79	20.0	1.14	29.0

¹±0.45 mm, ²To IEC 72-1, ³±0.25 mm, ⁴±1.1 mm, ⁵±0.4 mm

Unimotor fm 230 V 190 mm Frame Ratings

Motor Frame Size (mm)		190E3			
Voltage (Vrms)		230			
Frame Length		B	D	F*	H*
Continuous Stall Torque (lb-in)		199.1	393.8	557.6	686.8
Continuous Stall Torque (Nm)		22.5	44.5	63	77.0
Peak Torque (lb-in)		597.4	1181.5	1672.7	2044
Peak Torque (Nm)		67.5	133.5	189	231.0
Standard Inertia (lb-in-sec ²)		0.04408	0.07682	0.10957	0.1423
Standard Inertia (kgm ²)		0.00498	0.00868	0.01238	0.01608
High Inertia Option (lb-in-sec ²)		0.07815	0.1109	0.14365	0.01993
High Inertia Option (kgm ²)		0.00883	0.01253	0.01623	0.1437
Winding Thermal Time Const. (s)		214	216	285	564
Motor Weight (lbs)		48	70	90.2	111.3
Motor Weight (kg)		21.8	31.8	41	50.6
Shaft Diameter (mm)		32	32	32	32
Shaft Length† (mm)		58 or 80	58 or 80	58 or 80	58 or 80
2000 rpm	Kt (lb-in/A) =	12.4			
	Kt (Nm/A) =	1.4			
	Ke (V/k rpm) =	85.5			
Rated Torque (lb-in)		182.3	335.4	446.9*	495.6*
Rated Torque (Nm)		20.6	37.9	50.5	56.0
Stall Current (A)		16.1	31.8	45.0	55.0
Rated Power (kW)		4.31	7.94	10.58	11.73
R (ph-ph) (Ohms)		0.5	0.19	0.1	0.054
L (ph-ph) (mH)		0.77	3.26	2.65	1.55
3000 rpm	Kt (lb-in/A) =	8.2			
	Kt (Nm/A) =	0.93			
	Ke (V/k rpm) =	57.0			
Rated Torque (lb-in)		171.7	293.8*		
Rated Torque (Nm)		19.4	33.2		
Stall Current (A)		24.19	47.85		
Rated Power (kW)		6.09	10.43		
R (ph-ph) (Ohms)		0.26	0.09		
L (ph-ph) (mH)		3.87	1.81		

NOTES:

- * Ratings shown require connector option "H"
- Δt = 212 °F (100 °C) winding 104 °F (40 °C) maximum ambient
- All data subject to ±10% tolerance
- Stall torque, rated torque and power relate to maximum continuous operation tested in a 68 °F (20 °C) ambient at 12 kHz drive switching frequency
- Emerson has an ongoing process of development and reserves the right to change the specification without notice
- All other figures relate to a 68 °F (20 °C) motor temperature; maximum intermittent winding temperature is 284 °F (140 °C)

†Order Code Information for 230/460 V 190 mm Frame

The Unimotor E3/U3 190 frame models are now supplied with an 58 mm long output shaft. If replacing an existing Unimotor fm 190 E2/U2 model which has a standard 80 mm long output shaft add the suffix -SREM to the order code.

80mm long output shaft order code example:		shaft length	shaft diameter	notes
Unimotor fm E3/U3	190U3D300BACAA215320	58 mm	32 mm	New standard offering
Unimotor fm E2/U2 (replacement)	190U3D300JACAA215320-SREM	80 mm	32 mm	Previous standard offering

Unimotor fm 460 V 190 mm Frame Ratings

Motor Frame Size (mm)	190U3							
Voltage (Vrms)	460							
Frame Length	A	B	C	D	E	F	G*	H*
Continuous Stall Torque (lb-in)	100	199.1	296.5	393.8	477.9	557.6	628.4	681.5
Continuous Stall Torque (Nm)	11.3	22.5	33.5	44.5	54	63	71	77
Peak Torque (lb-in)	299.1	597.4	889.4	1181.5	1433.7	1672.7	1885.1	2044.4
Peak Torque (Nm)	33.8	67.5	100.5	133.5	162	189	213	231
Standard Inertia (lb-in-sec ²)	0.0277	0.04408	0.06045	0.07682	0.0932	0.10957	0.12595	0.14232
Standard Inertia (kgm ²)	0.00313	0.00498	0.00683	0.00868	0.01053	0.01238	0.01423	0.01608
High Inertia Option (lb-in-sec ²)	0.06178	0.07815	0.09453	0.1109	0.12727	0.14365	0.16002	0.1764
High Inertia Option (kgm ²)	0.00698	0.00883	0.01068	0.01253	0.01438	0.01623	0.01808	0.01993
Winding Thermal Time Const. (s)	194	214	215	216	251	285	425	564
Motor Weight (lbs)	37.4	48	58.5	69.1	79.6	90.2	100.8	111.3
Motor Weight (kg)	17	21.8	26.6	31.4	36.2	41	45.8	50.6
Shaft Diameter (mm)	32	32	32	32	32	32	32	32
Shaft Length† (mm)	58 or 80	58 or 80	58 or 80	58 or 80	58 or 80	58 or 80	58 or 80	58 or 80
2000 rpm	Kt (lb-in/A) =	21.24						
	Kt (Nm/A) =	2.40						
	Ke (V/k rpm) =	147.0						
Rated Torque (lb-in)	95.6	182.3	260.2	335.4	392.1	446.9	477.9	495.6
Rated Torque (Nm)	10.8	20.6	29.4	37.9	44.3	50.5	54.0	56.0
Stall Current (A)	4.7	9.4	14.0	18.5	22.5	26.3	29.6	32.1
Rated Power (kW)	2.26	4.31	6.15	7.94	9.28	10.58	11.31	11.73
R (ph-ph) (Ohms)	6.15	1.54	0.83	0.5	0.37	0.28	0.26	0.23
L (ph-ph) (mH)	52.9	23.55	15.0	8.81	8.68	7.36	6.89	6.3
3000 rpm	Kt (lb-in/A) =	14.2						
	Kt (Nm/A) =	1.60						
	Ke (V/k rpm) =	98.0						
Rated Torque (lb-in)	91.2	171.7	234.5	293.8	302.7	311.5	320.4*	327.5*
Rated Torque (Nm)	10.3	19.4	26.5	33.2	34.2	35.2	36.2	37.0
Stall Current (A)	7.0	14.1	20.9	27.8	33.8	39.4	44.4	48.1
Rated Power (kW)	3.24	6.09	8.33	10.43	10.74	11.06	11.37	11.62
R (ph-ph) (Ohms)	2.73	0.7	0.41	0.22	0.17	0.14	0.15	0.08
L (ph-ph) (mH)	23.5	10.47	7.35	4.89	3.86	3.6	3.06	2.42
4000 rpm	Kt (lb-in/A) =	10.6						
	Kt (Nm/A) =	1.20						
	Ke (V/k rpm) =	73.5						
Rated Torque (lb-in)	72.6	161.1	203.6	256.7				
Rated Torque (Nm)	8.2	18.2	23.0	29.0				
Stall Current (A)	9.4	18.8	27.9	37.1				
Rated Power (kW)	3.43	7.62	9.63	12.15				
R (ph-ph) (Ohms)	1.35	0.38	0.21	0.14				
L (ph-ph) (mH)	13.56	6.05	3.86	2.45				

NOTES:

- * Ratings shown require connector option "H"
- $\Delta t = 212\text{ }^{\circ}\text{F}$ (100 $^{\circ}\text{C}$) winding 104 $^{\circ}\text{F}$ (40 $^{\circ}\text{C}$) maximum ambient
- All data subject to $\pm 10\%$ tolerance
- Stall torque, rated torque and power relate to maximum continuous operation tested in a 68 $^{\circ}\text{F}$ (20 $^{\circ}\text{C}$) ambient at 12 kHz drive switching frequency
- Emerson has an ongoing process of development and reserves the right to change the specification without notice
- All other figures relate to a 68 $^{\circ}\text{F}$ (20 $^{\circ}\text{C}$) motor temperature; maximum intermittent winding temperature is 284 $^{\circ}\text{F}$ (140 $^{\circ}\text{C}$)

Unimotor fm 230 V and 460 V 190 mm Frame Dimensions

NOTE: Output key dimensions (E,F,G and H) are applicable to keyed units only. 90° connectors are standard

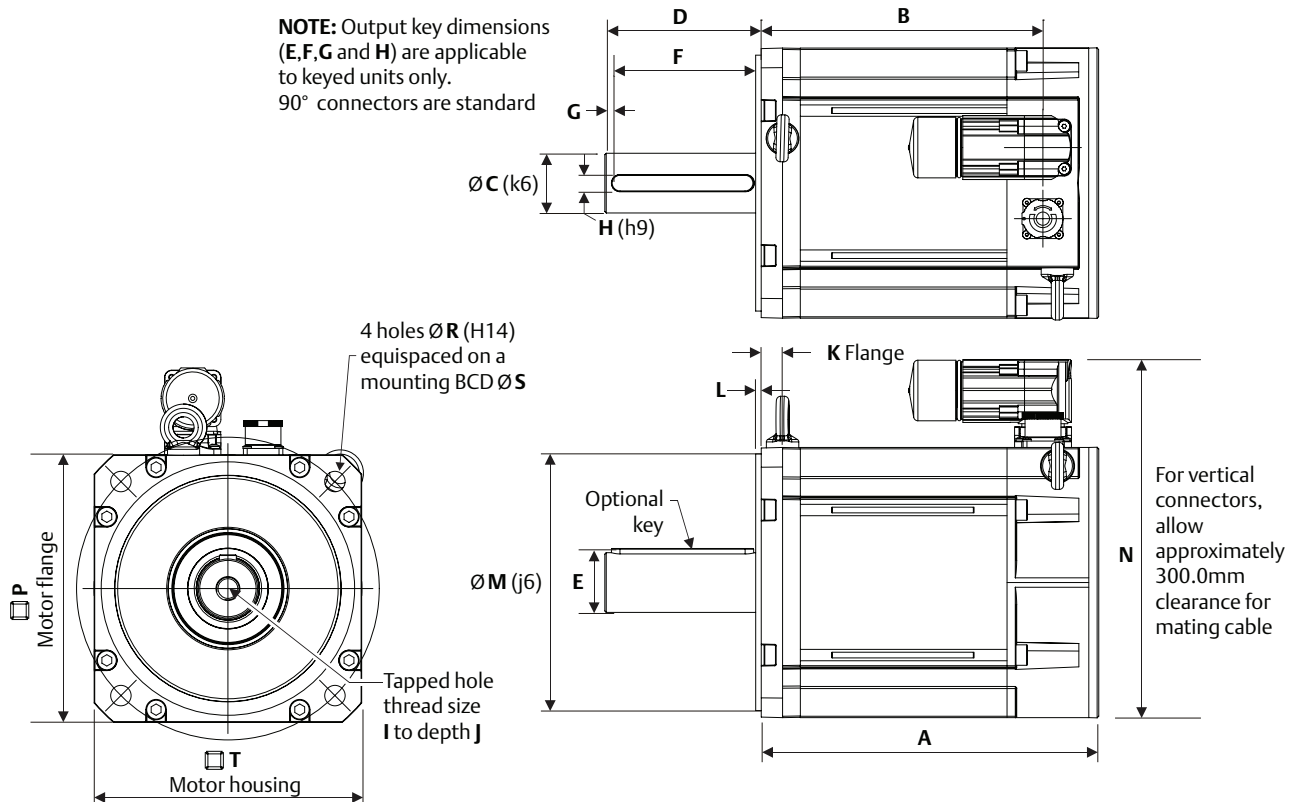

Motor Dimensions		Frame Length															
		A		B		C		D		E		F		G		H	
		(in)	(mm)	(in)	(mm)	(in)	(mm)	(in)	(mm)	(in)	(mm)	(in)	(mm)	(in)	(mm)	(in)	(mm)
Unbraked Length	A	7.85	199.4	9.03	229.4	10.21	259.4	11.39	289.4	12.57	319.4	13.76	349.4	14.94	379.4	16.12	409.4
	B	6.68	169.6	7.86	199.6	9.04	229.6	10.22	259.6	11.4	289.6	12.58	319.6	13.76	349.6	14.94	379.6
Braked Length	A	11.39	289.4	12.57	319.4	13.76	349.4	14.94	379.4	16.12	409.4	17.3	439.4	18.48	469.4	19.66	499.4
	B	10.22	259.6	11.4	289.6	12.58	319.6	13.76	349.6	14.94	379.6	16.13	409.6	17.31	439.6	18.49	469.6

Connector Type	Connector Size	Connector Height	
		(in)	(mm)
"A"	N	1.5	9.65
"J" (std)		1.5	9.94
"N"		1.5	9.94
"M"		1.5	9.13

Flange Dimensions		BCD Code	
		Standard	
		215	
		(in)	(mm)
Flange Thickness	K	0.73	18.5
Pilot Thickness	L	0.15	3.9
Pilot Diameter (j6)	M	7.09	180.0
Flange Square	P	7.48	190.0
Mounting Hole Diameter (H14)	R	.057	14.5
Mounting Hole BCD	S	8.46	215.0
Motor Housing	T	7.48	190.0
Mounting Bolts		M12	

Shaft Dimensions		Shaft Diameter Code					
		32.0 mm Frames A-H		32.0 mm Frame A-H Opt.		38.0 mm Opt.	
		(in)	(mm)	(in)	(mm)	(in)	(mm)
Shaft Diameter (j6)	C	1.26	32	1.26	32	1.5	38
Shaft Length	D ¹	2.28	58	3.15	80	2.28	58
Key Height	E ²	1.61	41	1.61	41	1.61	41
Key Length	F ³	2.76	7.0	2.76	70	2.76	70
Key-to-Shaft End	G ⁴	0.18	4.6	0.18	4.6	0.18	4.6
Key Width (H9)	H	0.39	10	0.39	10	0.39	10
Tapped Hole Thread Size	I	M12 x 1.75		M12 x 1.75		M12 x 1.75	
Tapped Hole Depth	J ⁵	1.14	29	1.14	29	1.14	29

¹±0.45 mm, ²To IEC 72-1, ³±0.25 mm, ⁴±1.1 mm, ⁵±0.4 mm

Unimotor fm 250 mm Frame Ratings

Motor Frame Size (mm)		250U3		
Voltage (Vrms)		460		
Frame Length		D	E	F
Continuous Stall Torque (lb-in)		814	1027	1204
Continuous Stall Torque (Nm)		92	116	136
Peak Torque (lb-in)		2443	3080	3611
Peak Torque (Nm)		276	348	408
Standard Inertia (lb-in-sec ²)		0.243	0.298	0.354
Standard Inertia (kgm ²)		0.028	0.034	0.04
High Inertia (lb-in-sec ²)		0.361	0.444	0.528
High Inertia (kgm ²)		0.041	0.050	0.060
Winding Thermal Time Const. (s)		439	486	608
Motor Weight (lbs)		126.5	144.1	162.1
Motor Weight (kg)		57.5	65.5	73.7
Shaft Diameter (mm)		48	48	48
Shaft Length (mm)		110	110	110
1000 rpm	Kt (lb-in/A) =	47.8		
	Kt (Nm/A) =	5.4		
	Ke (V/k rpm) =	323		
Rated Torque (lb-in)		664	814	938
Rated Torque (Nm)		75	92	106
Stall Current (A)		17.2	21.7	25.4
Rated Power (kW)		7.9	9.6	11.1
R (ph-ph) (Ohms)		0.61	0.48	0.34
L (ph-ph) (mH)		22.9	19.1	14.9
1500 rpm	Kt (lb-in/A) =	31.9		
	Kt(Nm/A) =	3.6		
	Ke (V/k rpm) =	216		
Rated Torque (lb-in)		593	673	743
Rated Torque (Nm)		67	76	84
Stall Current (A)		25.8	32.5	38.1
Rated Power (kW)		10.5	11.9	13.2
R (ph-ph) (Ohms)		0.27	0.21	0.15
L (ph-ph) (mH)		10.0	8.6	6.6
2000 rpm	Kt (lb-in/A) =	23.9		
	Kt (Nm/A) =	2.7		
	Ke (V/k rpm) =	162		
Rated Torque (lb-in)		593	655	717
Rated Torque (Nm)		67	74	81
Stall Current (A)		34.4	43.4	50.9
Rated Power (kW)		10.2	11.5	12.7
R (ph-ph) (Ohms)		0.15	0.10	0.08
L (ph-ph) (mH)		5.7	4.2	3.7
2500 rpm	Kt (lb-in/A) =	18.6		
	Kt (Nm/A) =	2.1		
	Ke (V/k rpm) =	129		
Rated Torque (lb-in)		549	620	681
Rated Torque (Nm)		62	70	77
Stall Current (A)		43	54.2	63.6
Rated Power (kW)		9.7	11	12.1
R (ph-ph) (Ohms)		0.09	0.08	0.06
L (ph-ph) (mH)		3.5	3.1	2.6

NOTES:

- $\Delta t = 212\text{ }^{\circ}\text{F}$ (100 $^{\circ}\text{C}$) winding 104 $^{\circ}\text{F}$ (40 $^{\circ}\text{C}$) maximum ambient
- All data subject to $\pm 10\%$ tolerance
- Stall torque, rated torque and power relate to maximum continuous operation tested in a 68 $^{\circ}\text{F}$ (20 $^{\circ}\text{C}$) ambient at 12 kHz drive switching frequency
- Emerson has an ongoing process of development and reserves the right to change the specification without notice
- All other figures relate to a 68 $^{\circ}\text{F}$ (20 $^{\circ}\text{C}$) motor temperature; maximum intermittent winding temperature is 284 $^{\circ}\text{F}$ (140 $^{\circ}\text{C}$)

Unimotor fm 250 mm Frame Dimensions

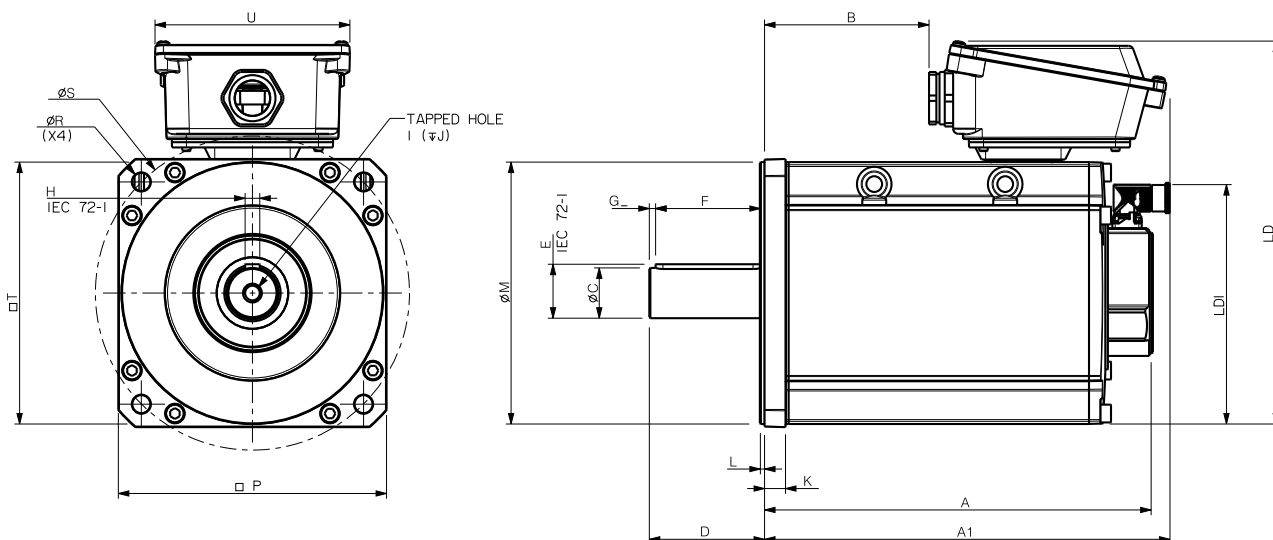

Motor Dimensions		Frame Length					
		D		E		F	
		(in)	(mm)	(in)	(mm)	(in)	(mm)
Unbraked Length	A	14.59	370.7	15.78	400.7	16.96	430.7
	A1	24.8	630.1	25.9	660.1	27.2	690.1
	B	7.07	179.7	8.26	209.7	9.44	239.7
Braked Length	A	17.42	442.5	18.60	472.5	19.78	502.5
	A1	27.6	701.9	28.8	731.9	30.0	761.9
	B	9.90	251.5	11.08	281.5	12.26	311.5

Connector Type	Connector Height			
	LD		LD1	
	(in)	(mm)	(in)	(mm)
"V"	11.48	291.5	8.70	221
"C"	12.30	312.5	8.70	221
"B"	12.30	312.5	8.70	221
"H" (std)	14.3	363.5	8.70	221

Flange Dimensions		BCD Code	
		Standard	
		215	
		(in)	(mm)
Flange Thickness	K	0.79	20.0
Pilot Thickness	L	0.18	4.50
Pilot Diameter (J6)	M	9.84	250.0
Flange Square	P	10.08	256.0
Mounting Hole Diameter (H14)	R	0.73	18.5
Mounting Hole BCD	S	11.81	300.0
Motor Housing	T	9.82	249.5
Terminal Box Width	U	7.32	186.0
Mounting Bolts		M16	

Shaft Dimensions		Shaft Diameter Code					
		38.0 mm Opt.		42.0 mm Opt.		48.0 mm standard	
		(in)	(mm)	(in)	(mm)	(in)	(mm)
Shaft Diameter (J6)	C	1.50	38.0	1.65	42.0	1.89	48.0
Shaft Length	D ¹	3.15	80.0	4.33	110.0	4.33	110.0
Key Height	E ²	1.61	41.0	1.77	45.0	2.03	51.5
Key Length	F ³	2.76	70.0	3.94	100.0	3.94	100.0
Key-to-Shaft End	G ⁴	0.18	4.6	0.24	6.0	0.24	6.0
Key Width (H9)	H	0.39	10.0	0.47	12.0	0.55	14.0
Tapped Hole Thread Size	I	M12x1.75mm		M16x2.0mm		M16x2.0mm	
Tapped Hole Depth	J ⁵	1.46	37.0	1.46	37.0	1.14	29.0

¹±0.45 mm, ²To IEC 72-1, ³±0.25 mm, ⁴±1.1 mm, ⁵±0.4 mm

NOTE: Shaft options below the standard (Std) dimensions will require customer approval and may not be covered by warranty.

Unimotor fm Motor Selection Considerations

Feedback

Feedback Device Order Code	Feedback Type	Encoder Supply Voltage	SinCos Cycles or Incremental Pulses per Revolution	Resolution Available to Position Loop	Feedback Accuracy
075-250 motors					
				Medium	Medium
AE	Resolver ¹	6 Vrms Excitation 6 kHz	1	16384 (14 bit)	+/- 720 arc second
				Medium	High
CA	Incremental Encoder	5 Vdc	4096	16384 (14 bit)	+/- 60 arc second
				High	Medium
EC (Multi-turn)	Inductive Absolute Encoder EnDat ²	5 Vdc	32	Absolute position 524288	+/- 280 arc second
FC (Single-turn)				(19 bits)	
				Very high	High
RA (Multi-turn)	Optical SinCos Encoder HIPERFACE ²	7 - 12 Vdc	1024	1.04 x 10 ⁶	+/-52 arc second
SA (Single-turn)				(20 bits)	
				Very High	Very High
EB (Multi-turn)	Optical Absolute Encoder EnDat ²	3.6 - 14 Vdc	2048	2.08 x 10 ⁶	+/-20 arc second (Differential non linearity +/- 1% signal period)
FB (Single-turn)				(21 bits)	

NOTES:

¹Resolution value shown when used with the Unidrive M resolver input or SM-Resolver Option Module (Unidrive Sp and Digitax ST)

²Resolution value shown when used with the Unidrive M, Unidrive SP or Digitax ST when the encoder type is set to either SC EnDat or SC Hiper, depending on the encoder. Multi-turn devices have 4096 (12 bit) resolution.

Motor Selection Considerations

Motor Selection

Motor Derating

Any adverse operating conditions require that the motor performance be derated. These conditions include ambient temperature above 104 °F (40 °C), motor mounting position, drive switching frequency or a drive oversized for the motor.

Ambient Temperatures

For ambient temperatures above 104 °F (40 °C), the torque must be derated using the following formula as a guideline (only applies to motors up to 3000 rpm and assumes copper losses dominate).

$$\text{New derated torque} = \text{Specified torque} \times \sqrt{1 - \frac{(\text{ambient temperature} - 40)}{100}}$$

*Measured in °C

For example, with an ambient temperature of 169 °F (76 °C), the new derated torque will be 0.8 x specified torque.

Drive Switching Frequency

Most drive current ratings are reduced at higher switching frequencies. See individual drive manuals for details.

Most motor current ratings are reduced at lower switching frequencies. See the table below for motor derating factors (these figures are for guidance only).

Ingress Protection

IP65 conformance; sealed against water spray and dust when mounted and connected.

Unimotor fm Motor Derating Factors

Switching Frequency	Frame Length									
	075		095		115		142		190	
	A-D	A-E	A-C	D-E	A-C	D-E	A-B	C-H	D-F	
3 kHz	0.93	0.88	0.89	0.84	0.87	0.81	0.98	N/A	0.88	
4 kHz	0.94	0.91	0.91	0.87	0.91	0.86	0.99	0.55	0.90	
5/6 kHz	0.95	0.93	0.93	0.90	0.94	0.89	0.99	0.77	0.94	
8 kHz	0.98	0.97	0.97	0.95	0.97	0.96	1	0.90	0.98	
10/12/16 kHz	1	1	1	1	1	1	1	1	1	

Unimotor fm Motor Holding Brake Specifications

Motor Frame Size	Power Supply	Input Power	Static Torque		Mechanical Release Time	Added Inertia		Added Weight		Degress
(mm)	(Vdc)	(W)	(lb-in)	(Nm)	(ms)	(lb-in-sec ²)	(kgcm ²)	(lb)	(kg)	(°)
75	24	6.3	19.5	2.2	22	0.00006	0.07	1.1	0.5	1.03
95	24	16	108	12.2	60	0.00035	0.39	1.3	0.6	0.94
115	24	23	177	20	120	0.00039	0.24	2.6	1.2	0.75
142	24	23	177	20	120	0.00048	0.3	3.7	1.7	0.75
190 (A-D)	24	25	221	42	95	0.00035	0.39	4.4	2.0	0.77
190 (E-H)	24	25	548	67	120	0.00035	0.39	4.4	2.0	0.77
250	24	62	1195	135	250	0.01452	16.4	24.2	11.0	0.5

NOTES:

- Figures shown in individual motor sections are at 68 °F (20 °C) ambient
- Apply a derate factor of 0.7 to standard brake torque figures if motor temperature is above 212 °F (100 °C)
- *Backlash will increase over time

Thermal Protection

Thermistor protection to 293 °F (145 °C) is built into the motor windings and gives an indication of serious overheating problems.

The installer must connect the thermistor to the drive. Failure to do so will invalidate the motor warranty if winding burns out.

Environmental Conditions

Any liquids or gases that may come into contact with the motor must be confirmed to ensure compliance with the correct international standards.

Brake Operation

Do not apply the brake while the motor shaft is rotating. The brake can only take a limited number of emergency braking operations and must not be used for repeated dynamic braking.

Thermal Test Conditions

In general, motor torque should be derated if the motor mounting surface is heated from an external source such as a gearbox, the motor is connected to a poor thermal conductor, or the motor is mounted in a confined space with restricted air flow.

Thermal motor mounting arrangement test example:

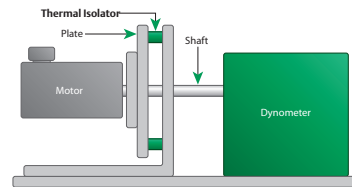

Motor Type/ Frame	Aluminum Heatsink Plate	
	(in)	(mm)
075-095	9.8 x 9.8 x 0.6	250 x 250 x 15
115-142	13.8 x 13.8 x 0.8	350 x 350 x 20
190	19.7 x 19.7 x 0.8	500 x 500 x 20

Unimotor hd 230 V | 460 V

Compact, Powerful High Dynamic AC Servo Motors

Designed for maximum torque density, the Unimotor hd brushless AC Servo motor series provides an exceptionally compact, low inertia solution for applications that require very high torque during rapid acceleration and deceleration profiles. Unimotor hd motors fitted with high resolution SinCos or absolute encoders are pre-loaded with the motor “electronic nameplate” data during the manufacturing process. This data can be read by most Control Techniques' brand servo drives and used to automatically optimize the drive settings. This feature simplifies commissioning and maintenance, ensures consistent performance and saves time.

The Unimotor hd torque profile is closely matched to Digitax ST Servo drives providing up to 300% peak overload for maximum dynamic performance.

Key Features

- Torque range: 6.4 to 752 lb-in (0.72 to 85.0 Nm)
- High torque-to-inertia ratio for high-dynamic performance
- Compact and powerful
- Optional holding brake
- IP65 conformance
- Segmented stator design
- World class performance
- Winding to suit 230 V and 460 V
- Speeds include 2000, 3000, 4000 and 6000 rpm
- Large shafts to increase torsional rigidity
- Multiple feedback options:
 - Incremental encoder: High accuracy, medium resolution
 - Absolute: Medium accuracy, medium resolution, single-turn and multi-turn
 - SinCos/absolute: High accuracy, high resolution, single-turn and multi-turn
 - HIPERFACE (SICK) and EnDat (Heidenhain) protocols supported
 - Resolver: Robust for extreme applications and conditions; lower accuracy, medium resolution

Approvals



Unimotor hd



Unimotor hd motors (shown with a Digitax ST Servo drive).

Unimotor hd Torque Range

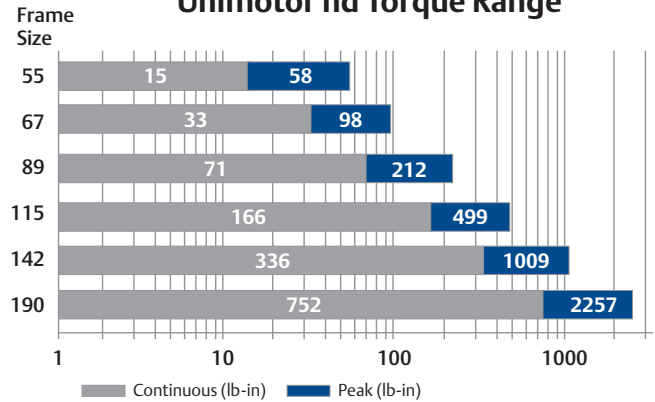

All Unimotor hd motors feature connections that rotate for easier cable routing and installation.

UNIMOTOR HD

Unimotor hd 230 V | 460 V

Order Code information

Use the information below to create an order code for a Unimotor hd (top row is an example).

089	UD	B	30	5	B	A	CA		A	BCD	Shaft Diameter		
Frame Size	Motor Voltage	Stator Length 055 - 089 Frames	Speed 055 - 067 Frames	Brake (24 V) 055 - 190 Frames	Connection Type 055 - 115 Frames	Output Shaft	Feedback Device		Inertia	063	Shaft Diameter		
							055 Frame					055 Frame Only†	
055	ED = 230 V	A	30 = 3000 rpm	0 = Not Fitted	B = Power size 1.0 and Signal 90° and Rotatable	A = Keyway w/ full key installed	CR = Incremental Encoder (Renco) **	4096 ppr (R35i)	A = Std.		9.0 A-C		
067	UD = 460 V	B	60 = 6000 rpm	5 = Holding Brake**	B = Power size 1.0 and Signal 90° and Rotatable	F=Keyway w/ full & half key* provided	EM = SinCos Multi-Turn	EQI 1130 - EnDat			11.0 A-C		
089		C	089 Frame				FM = SinCos Single-Turn	ECI 1118 - EnDat					14.0 A-C
115		115 Frame	30 = 3000 rpm				AR = Resolver						
142		B	40 = 4000 rpm				67 Frame						
190		C	60 = 6000 rpm				CR = Incremental Encoder (Renco) **	4096 ppr (R35i)					
		D	115 Frame				EM = SinCos Multi-Turn	EQI 1130 - EnDat					
		142 Frame	20 = 2000 rpm				FM = SinCos Single-Turn	ECI 1118 - EnDat					
		C	30 = 3000 rpm				AR = Resolver						
		D	142 Frame				089 - 190 Frames						
		E	10 = 1000 rpm				CA = Incremental Encoder (SICK)	4096 ppr (CFS50)					
		190 Frame	15 = 1500 rpm	EC = SinCos Multi-Turn	EQI 1331 - EnDat								
		C	20 = 2000 rpm	EB = SinCos Multi-Turn	EQN 1325 - EnDat								
		D	30 = 3000 rpm	FB = SinCos Single-Turn	ECN 1313 - EnDat								
		F	190 Frame	FC = SinCos Single-Turn	ECI 1319 - EnDat								
			10 = 1000 rpm	RA = SinCos Multi-Turn	SRM 50 (GEN 2) - HIPERFACE								
			15 = 1500 rpm	SA = SinCos Single-Turn	SRS 50 (GEN 2) - HIPERFACE								
			20 = 2000 rpm	AE = Resolver									

NOTES:

*Half key provided to create a smooth shaft and balance

** Holding brakes are not designed for dynamic use

†Add BCD and Shaft Diameter code for 055 frame only (11 and 14 mm are standard)
ex. 055EDC600BACRA063110

The Unimotor hd series servo motor expands the capabilities of Emerson Industrial Automation motion systems that provide high torque in a small size as well as support for incremental encoders, absolute encoders and resolver motor feedback.

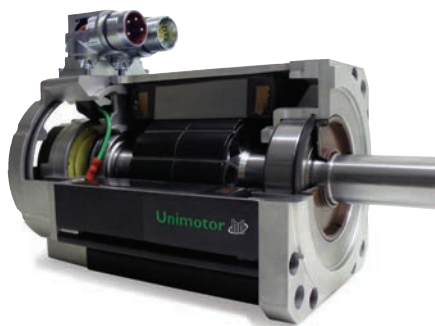

Unimotor hd 55 mm Frame Ratings and Dimensions

Motor Frame Size (mm)	055ED			055UD			
	230			460			
Voltage (Vrms)	230			460			
Frame Length	A	B	C	A	B	C	
Continuous Stall Torque (lb-in)	6.37	10.44	14.6	6.37	10.44	14.6	
Continuous Stall Torque (Nm)	0.72	1.18	1.65	0.72	1.18	1.65	
Peak Torque (lb-in)	25.49	41.78	58.42	25.49	41.78	58.42	
Peak Torque (Nm)	2.88	4.72	6.6	2.88	4.72	6.6	
Inertia (lb-in-sec ²)	0.00012	0.00022	0.00032	0.00012	0.00022	0.00032	
Inertia (kgm ²)	0.000014	0.000025	0.000036	0.000014	0.000025	0.000036	
Motor Weight (lb)	2.64	3.3	3.96	2.64	3.3	3.96	
Motor Weight (kg)	1.2	1.5	1.8	1.2	1.5	1.8	
Number of Poles	8	8	8	8	8	8	
3000 rpm	Kt (lb-in/A) =	6.55	7.7	8.05	6.55	13.19	14.6
	Kt (Nm/A) =	0.74	0.87	0.91	0.74	1.49	1.65
	Ke (V/k rpm) =	45	52.5	55	45	90	100
Rated Torque (lb-in)	6.2	9.29	13.1	6.2	9.29	13.1	
Rated Torque (Nm)	0.7	1.05	1.48	0.7	1.05	1.48	
Stall Current (A)	0.97	1.36	1.81	0.97	0.79	1	
Rated Power (hp)	0.29	0.44	0.62	0.29	0.44	0.62	
Rated Power (kW)	0.22	0.33	0.46	0.22	0.33	0.46	
R (ph-ph) (Ohms)	28.0	14.12	9.53	28.0	45.0	31.0	
L (ph-ph) (mH)	50.0	32.00	23.0	50.0	100.0	75.0	
6000 rpm	Kt (lb-in/A) =	3.98	3.81	4.25	6.55	6.99	7.35
	Kt (Nm/A) =	0.45	0.43	0.48	0.74	0.79	0.83
	Ke (V/k rpm) =	27	26	29	45	47.5	50
Rated Torque (lb-in)	6.02	7.97	10.62	6.02	7.97	10.62	
Rated Torque (Nm)	0.68	0.9	1.2	0.68	0.9	1.2	
Stall Current (A)	1.61	2.74	3.44	0.97	1.49	1.99	
Rated Power (hp)	0.58	0.76	1.01	0.58	0.76	1.01	
Rated Power (kW)	0.43	0.57	0.75	0.43	0.57	0.75	
R (ph-ph) (Ohms)	8.50	3.55	2.38	28.00	10.70	7.80	
L (ph-ph) (mH)	16.00	8.20	6.30	50.00	25.00	20.00	

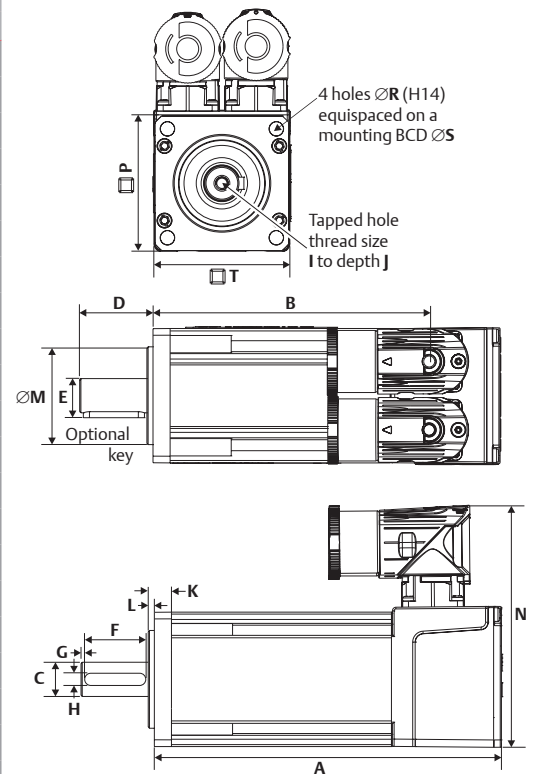

UNIMOTOR HD

Shaft Dimensions		Shaft Diameter Code					
		9.0 mm		11.0 mm		14.0 mm	
		(in)	(mm)	(in)	(mm)	(in)	(mm)
Shaft Diameter (J6)	C	0.354	9.0	0.433	11.0	0.551	14.0
Shaft Length	D	0.790	20.0	0.906	23.0	1.181	30.0
Key Height	E	0.402	10.2	0.492	12.5	0.629	16.0
Key Length	F	0.591	15.0	0.591	15.0	0.886	22.0
Key-to-Shaft End	G	0.039	1.0	0.059	1.5	0.142	3.6
Key Width (H9)	H	0.118	3.0	0.157	4.0	0.197	5.0
Tapped Hole Thread Size	I	M4 x 10		M4 x 10		M5 x 12.5	
Tapped Hole Depth	J	0.394	10.0	0.531	13.5	0.492	12.5

Motor Dimensions		Frame Length					
		A		B		C	
		(in)	(mm)	(in)	(mm)	(in)	(mm)
Unbraked Length	A	4.65	118	5.59	142	6.54	166
	B	3.55	90	4.49	114	5.43	138
Braked Length	A	6.22	158	7.17	182	8.11	206
	B	5.12	130	6.06	154	7.01	178

Flange Dimensions		BCD Code	
		Standard	
		063	
		(in)	(mm)
Flange Thickness	K	0.276	7.0
Pilot Thickness	L	0.098	2.5
Pilot Diameter (J6)	M	1.584	40.0
Flange Square	N	3.897	99.0
Mounting Hole Diameter (H14)	P	2.165	55.0
Mounting Hole BCD	R	0.228	5.8
Motor Housing	S	2.480	63.0
Terminal Box Width	T	2.115	55.0
Mounting Bolts		M5	

Unimotor hd 67 mm Frame Ratings and Dimensions

Motor Frame Size (mm)		067ED			067UD		
Voltage (Vrms)		230			460		
Frame Length		A	B	C	A	B	C
Continuous Stall Torque (lb-in)		12.8	22.6	32.7	12.8	22.5	32.7
Continuous Stall Torque (Nm)		1.45	2.55	3.70	1.45	2.55	3.70
Peak Torque (lb-in)		38.5	67.7	98.2	38.5	67.7	98.2
Peak Torque (Nm)		4.35	7.65	11.10	4.35	7.65	11.10
Inertia (lb-in-sec ²)		0.00027	0.00047	0.00066	0.00027	0.00047	0.00066
Inertia (kgm ²)		0.000030	0.000053	0.000075	0.000030	0.000053	0.000075
Motor Weight (lb)		4.40	5.72	7.04	4.41	5.73	7.05
Motor Weight (kg)		2.00	2.60	3.20	2.00	2.60	3.20
Number of Poles		10	10	10	10	10	10
3000 rpm	Kt (lb-in/A) =	8.23			7.08	14.16	
	Kt (Nm/A) =	0.93			0.80	1.60	
	Ke (V/k rpm) =	57.0			49.0	98.0	
Rated Torque (lb-in)	12.4	21.7	31.0	12.4	21.7	31.0	
Rated Torque (Nm)	1.40	2.45	3.50	1.40	2.45	3.50	
Stall Current (A)	1.56	2.74	3.98	1.81	1.59	2.31	
Rated Power (hp)	0.59	1.03	1.48	0.59	1.03	1.48	
Rated Power (kW)	0.44	0.77	1.10	0.44	0.77	1.10	
R (ph-ph) (Ohms)	14.92	4.88	3.33	11.69	15.20	10.70	
L (ph-ph) (mH)	45.43	17.40	12.70	35.18	54.20	40.80	
6000 rpm	Kt (lb-in/A) =	4.16			7.08		
	Kt (Nm/A) =	0.47			0.80		
	Ke (V/k rpm) =	28.5			49.0		
Rated Torque (lb-in)	11.5	19.5		11.5	19.5	27.4	
Rated Torque (Nm)	1.30	2.20		1.30	2.20	3.10	
Stall Current (A)	3.12	5.48		1.81	3.19	4.63	
Rated Power (hp)	1.10	1.85		1.10	1.85	2.61	
Rated Power (kW)	0.82	1.38		0.82	1.38	1.95	
R (ph-ph) (Ohms)	3.86	1.22		11.69	3.79	2.68	
L (ph-ph) (mH)	11.06	4.35		35.18	13.60	10.20	

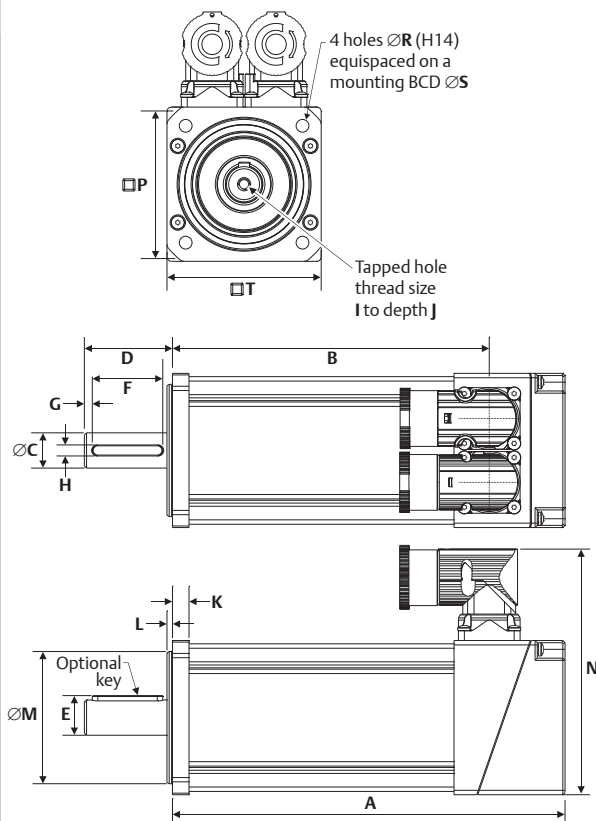

- NOTES:
- $\Delta t = 212^\circ\text{F}$ (100°C) winding 104°F (40°C) maximum ambient; all data subject to +/-10% tolerance
 - Stall torque, rated torque and power relate to maximum continuous operation tested in a 68°F (20°C) ambient above 12 kHz drive switching frequency
 - Maximum intermittent winding temperature is 284°F (140°C)

Shaft Dimensions	Shaft Diameter Code	
	14.0 mm	
	(in)	(mm)
Shaft Diameter	C	0.551 14.0
Shaft Length	D	1.181 30.0
Key Height	E	0.629 16.0
Key Length	F	0.964 25.0
Key-to-Shaft End	G	0.142 3.6
Key Width	H	0.197 5.0
Tapped Hole Thread Size	I	M5 x 0.8
Tapped Hole Depth	J	0.53 13.5

Motor Dimensions	Frame Length						
	A		B		C		
	(in)	(mm)	(in)	(mm)	(in)	(mm)	
Unbraked Length	A	5.62	142.7	6.80	172.7	7.98	202.7
	B	4.28	108.8	5.46	138.8	6.65	168.8
Braked Length	A	7.00	177.7	8.18	207.7	9.37	237.7
	B	5.66	143.8	6.84	173.8	8.02	203.8

Flange Dimensions	BCD Code	
	Standard	
	075	
	(in)	(mm)
Flange Thickness	K	0.295 7.5
Pilot Thickness	L	0.098 2.5
Pilot Diameter	M	2.362 60.0
Overall Height	N	4.389 111.5
Flange Square	P	2.755 70.0
Mounting Hole Diameter	R	0.228 5.8
Mounting Hole BCD	S	2.953 75.0
Motor Housing	T	2.637 67.0
Mounting Bolts		M5

Unimotor hd 89 mm Frame Ratings and Dimensions

Motor Frame Size (mm)	089ED			089UD		
	230			460		
Voltage (Vrms)	A	B	C	A	B	C
Frame Length						
Continuous Stall Torque (lb-in)	28.3	48.7	70.8	28.3	48.7	70.8
Continuous Stall Torque (Nm)	3.20	5.50	8.00	3.20	5.50	8.00
Peak Torque (lb-in)	85.0	146.0	212.4	85.0	146.0	212.4
Peak Torque (Nm)	9.60	16.50	24.00	9.60	16.50	24.00
Inertia (lb-in-sec ²)	0.00077	0.00142	0.00207	0.00077	0.00142	0.00207
Inertia (kgm ²)	0.000087	0.000161	0.000234	0.000087	0.000161	0.000234
Motor Weight (lb)	6.8	9.2	11.7	6.8	9.2	11.7
Motor Weight (kg)	3.30	4.40	5.50	3.30	4.40	5.50
Number of Poles	10	10	10	10	10	10
3000 rpm	Kt (lb-in/A) =			14.2		
	Kt (Nm/A) =			1.60		
	Ke (V/k rpm) =			98.0		
4000 rpm	Rated Torque (lb-in)	26.6	42.9	61.1	26.6	42.9
	Rated Torque (Nm)	3.0	4.85	6.90	3.00	4.85
	Stall Current (A)	3.44	5.91	8.60	2.00	3.44
	Rated Power (hp)	1.26	2.04	2.91	1.26	2.04
	Rated Power (kW)	0.94	1.52	2.17	0.94	1.52
	R (ph-ph) (Ohms)	3.28	1.57	0.89	10.10	5.05
	L (ph-ph) (mH)	21.55	11.84	7.09	65.17	38.36
	Kt (lb-in/A) =			10.6		
	Kt (Nm/A) =			1.20		
	Ke (V/k rpm) =			73.5		
6000 rpm	Rated Torque (lb-in)	25.7	40.3	56.2	25.7	40.3
	Rated Torque (Nm)	2.90	4.55	6.35	2.90	4.55
	Stall Current (A)	4.57	7.86	11.43	2.67	4.58
	Rated Power (hp)	1.62	2.56	3.57	1.62	2.56
	Rated Power (kW)	1.21	1.91	2.66	1.21	1.91
	R (ph-ph) (Ohms)	2.04	0.79	0.54	6.16	2.47
	L (ph-ph) (mH)	13.20	5.97	4.38	39.78	18.8
	Kt (lb-in/A) =			7.1		
	Kt (Nm/A) =			0.80		
	Ke (V/k rpm) =			49.0		
Rated Torque (lb-in)	23.5	33.6	44.3	23.5	33.6	
Rated Torque (Nm)	2.65	3.80	5.00	2.65	3.80	
Stall Current (A)	6.88	11.83	17.20	4.00	6.88	
Rated Power (hp)	2.24	3.21	4.21	2.24	3.21	
Rated Power (kW)	1.67	2.39	3.14	1.67	2.39	
R (ph-ph) (Ohms)	0.98	0.39	0.23	2.52	1.27	
L (ph-ph) (mH)	6.24	2.96	1.89	16.29	9.59	

NOTES:

- $\Delta t = 212^\circ\text{F}$ (100°C) winding 104°F (40°C) maximum ambient; all data subject to +/-10% tolerance
- Stall torque, rated torque and power relate to maximum continuous operation tested in a 68°F (20°C) ambient above 12 kHz drive switching frequency
- Maximum intermittent winding temperature is 284°F (140°C)

* Motor length increases 0.512 in (13 mm) for feedback options FB, EB, CA, SA and RA; motor length decreases 0.394 in (10 mm) for feedback option AE

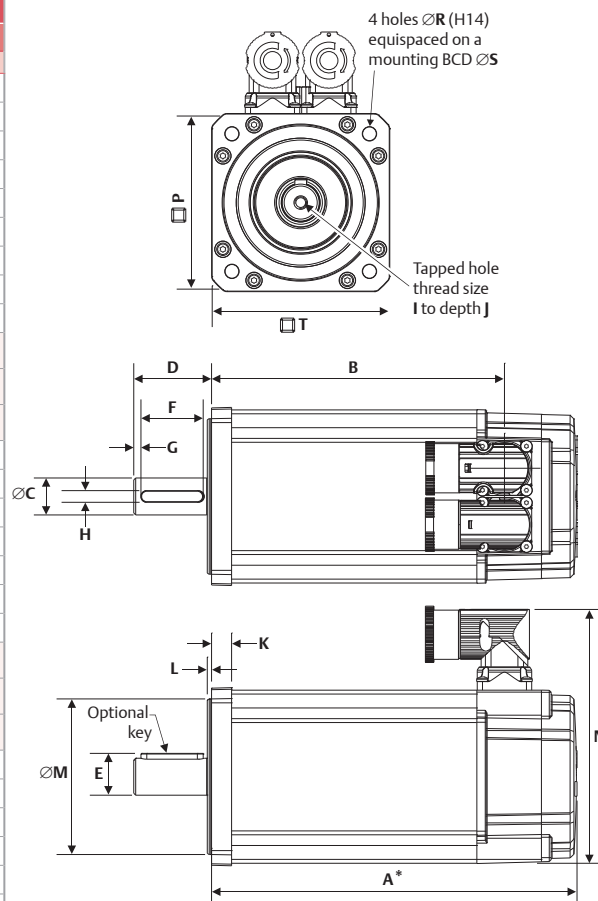

UNIMOTOR HD

Motor Dimensions		Frame Length						
		A		B		C		
		(in)	(mm)	(in)	(mm)	(in)	(mm)	
Feedback EC and FC only*	Unbraked Length	A*	5.82	147.8	7.00	177.8	8.16	207.8
		B	4.35	110.5	5.53	140.5	6.71	170.5
	Braked Length	A*	7.40	187.9	8.58	217.9	9.76	247.9
		B	5.93	150.6	7.11	180.6	8.29	210.6
Flange Dimensions		(in)		(mm)				
Flange Thickness		K	0.406			10.3		
Pilot Thickness		L	0.087			2.2		
Pilot Diameter		M	3.150			80.0		
Overall Height		N	5.140			130.5		
Flange Square		P	3.583			91.0		
Mounting Hole Diameter		R	0.276			7.0		
Mounting Hole BCD		S	3.940			100.0		
Motor Housing		T	3.504			89.0		
Mounting Bolts		M6						
Shaft Dimensions		(in)		(mm)				
Shaft Diameter		C	0.750			19.0		
Shaft Length		D	1.575			40.0		
Key Height		E	0.850			21.5		
Key Length		F	1.260			32.0		
Key-to-Shaft End		G	0.146			3.7		
Key Width		H	0.236			6.0		
Tapped Hole Thread Size		I	M6 x 1.0					
Tapped Hole Depth		J	0.670			17.0		

Unimotor hd 115 mm Frame Ratings and Dimensions

Motor Frame Size (mm)	115ED			115UD		
	230			460		
Voltage (Vrms)	B	C	D	B	C	D
Frame Length						
Continuous Stall Torque (lb-in)	90.3	129.2	166.4	90.3	129.2	166.4
Continuous Stall Torque (Nm)	10.20	14.60	18.80	10.20	14.60	18.80
Peak Torque (lb-in)	270.8	387.6	499.1	270.8	387.6	499.1
Peak Torque (Nm)	30.60	43.80	56.40	30.60	43.80	56.40
Inertia (lb-in-sec ²)	0.00390	0.00566	0.00742	0.00391	0.00566	0.00742
Inertia (kgm ²)	0.000441	0.000639	0.000838	0.000441	0.000639	0.000838
Motor Weight (lb)	15.87	19.62	23.6	15.87	19.62	23.6
Motor Weight (kg)	7.20	8.90	10.70	7.20	8.90	10.70
Number of Poles	10	10	10	10	10	10
2000 rpm	Kt (lb-in/A) = 12.4			21.2		
	Kt (Nm/A) = 1.40			2.40		
	Ke (V/k rpm) = 85.5			147.0		
3000 rpm	Rated Torque (lb-in)	76.1	105.3	138.1	76.1	105.3
	Rated Torque (Nm)	8.60	11.90	15.60	8.60	11.90
	Stall Current (A)	7.29	10.43	13.43	4.25	6.08
	Rated Power (hp)	2.41	3.34	4.38	2.41	3.34
	Rated Power (kW)	1.80	2.49	3.27	1.80	2.49
	R (ph-ph) (Ohms)	1.40	0.77	0.61	4.41	2.41
	L (ph-ph) (mH)	12.84	7.87	6.62	40.59	24.69
	Kt (lb-in/A) = 8.2			14.2		
	Kt (Nm/A) = 0.93			1.60		
	Ke (V/k rpm) = 57.0			98.0		
	Rated Torque (lb-in)	68.2	92.9		68.2	92.9
Rated Torque (Nm)	7.70	10.50		7.70	10.50	
Stall Current (A)	10.97	15.70		6.38	9.13	
Rated Power (hp)	3.25	4.43		3.25	4.43	
Rated Power (kW)	2.42	3.30		2.42	3.30	
R (ph-ph) (Ohms)	0.58	0.39		1.83	1.21	
L (ph-ph) (mH)	5.40	4.01		16.93	12.72	

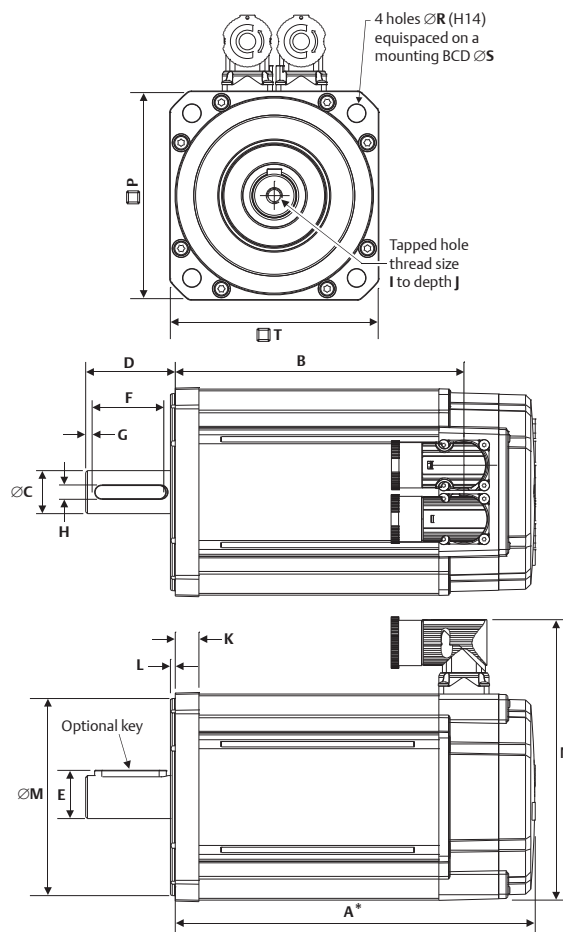

NOTES:

- $\Delta t = 212^\circ\text{F}$ (100°C) winding 104°F (40°C) maximum ambient; all data subject to +/-10% tolerance
- Stall torque, rated torque and power relate to maximum continuous operation tested in a 68°F (20°C) ambient above 12 kHz drive switching frequency
- Maximum intermittent winding temperature is 284°F (140°C)

Motor Dimensions		Frame Length						
		B		C		D		
		(in)	(mm)	(in)	(mm)	(in)	(mm)	
Feedback EC and FC only*	Unbraked Length	A*	7.63	193.8	8.81	223.8	9.99	253.8
		B	6.06	154.0	7.24	184.0	8.43	214.0
	Braked Length	A*	9.09	230.9	10.27	260.9	11.45	290.9
		B	7.52	191.1	8.70	221.1	9.89	251.1
Flange Dimensions		(in)		(mm)				
Flange Thickness	K	0.519		13.2				
Pilot Thickness	L	0.106		2.7				
Pilot Diameter	M	4.33		110.0				
Overall Height	N	6.16		156.5				
Flange Square	P	4.57		116.0				
Mounting Hole Diameter	R	0.394		10.0				
Mounting Hole BCD	S	5.12		130.0				
Motor Housing	T	4.53		115.0				
Mounting Bolts		M8						
Shaft Dimensions		(in)		(mm)				
Shaft Diameter	C	0.945		24.0				
Shaft Length	D	1.97		50.0				
Key Height	E	1.06		27.0				
Key Length	F	1.57		40.0				
Key-to-Shaft End	G	0.209		5.3				
Key Width	H	0.315		8.0				
Tapped Hole Thread Size	I	M8 x 1.25						
Tapped Hole Depth	J	0.79		20.0				

* Motor length increases 0.512 in (13 mm) for feedback options FB, EB, CA, SA and RA; motor length decreases 0.394 in (10 mm) for feedback option AE

Unimotor hd 142 mm Frame Ratings and Dimensions

Motor Frame Size (mm)		142ED			142UD		
Voltage (Vrms)		230			460		
Frame Length		C	D	E	C	D	E
Continuous Stall Torque (lb-in)		221.3	278.8	336.3	221.3	278.8	336.3
Continuous Stall Torque (Nm)		25.0	31.5	38.0	25.0	31.5	38.0
Peak Torque (lb-in)		662.9	836.4	1008.9	662.9	836.4	1008.9
Peak Torque (Nm)		74.9	94.5	114.0	74.9	94.5	114.0
Inertia (lb-in-sec ²)		.01505	.01956	.02407	.01505	.01956	.02407
Inertia (kgm ²)		.0017	.00221	.00272	.0017	.00221	.00272
Motor Weight (lb)		25.4	33.1	40.8	25.4	33.1	40.8
Motor Weight (kg)		11.5	15.0	18.5	11.5	15.0	18.5
Number of Poles		10	10	10	10	10	10
1000 rpm	Kt (lb-in/A) =	24.78					
	Kt (Nm/A) =	2.8					
	Ke (V/k rpm) =	171.0					
	Rated Torque (lb-in)	206.2	256.7	305.4			
	Rated Torque (Nm)	23.3	29.0	34.5			
	Stall Current (A)	8.9	11.2	13.6			
	Rated Power (hp)	3.27	4.08	4.84			
	Rated Power (kW)	2.44	3.04	3.61			
	R (ph-ph) (Ohms)	1.36	0.94	0.72			
	L (ph-ph) (mH)	21.34	15.17	12.3			
Connector Type		B					
1500 rpm	Kt (lb-in/A) =				28.32		
	Kt (Nm/A) =				3.2		
	Ke (V/k rpm) =				196.0		
	Rated Torque (lb-in)				197.4	238.9	280.6
	Rated Torque (Nm)				22.3	27.0	31.7
	Stall Current (A)				7.8	9.8	11.9
	Rated Power (hp)				4.69	5.63	6.71
	Rated Power (kW)				3.5	4.2	5.0
	R (ph-ph) (Ohms)				1.36	0.94	0.72
	L (ph-ph) (mH)				21.34	15.17	12.3
Connector Type					B		
2000 rpm	Kt (lb-in/A) =	12.39			21.24		
	Kt (Nm/A) =	1.4			2.4		
	Ke (V/k rpm) =	85.5			147.0		
	Rated Torque (lb-in)	189.4	227.5	261.9	189.4	227.5	261.9
	Rated Torque (Nm)	21.4	25.7	29.6	21.4	25.7	29.6
	Stall Current (A)	17.8	22.5	27.1	10.4	13.1	15.8
	Rated Power (hp)	6.01	7.21	8.31	6.01	7.21	8.31
	Rated Power (kW)	4.48	5.38	6.2	4.48	5.38	6.2
	R (ph-ph) (Ohms)	0.34	0.24	0.18	0.79	0.62	0.49
	L (ph-ph) (mH)	5.33	3.79	3.07	12.15	9.66	8.34
Connector Type		J*			B		
3000 rpm	Kt (lb-in/A) =	8.23			14.16		
	Kt (Nm/A) =	0.93			1.6		
	Ke (V/k rpm) =	57.0			98.0		
	Rated Torque (lb-in)	162.8	184.9		162.8	184.9	203.6
	Rated Torque (Nm)	18.4	20.9		18.4	20.9	23.0
	Stall Current (A)	26.9	33.9		15.6	19.7	23.8
	Rated Power (hp)	7.75	8.81		7.75	8.81	9.70
	Rated Power (kW)	5.78	6.57		5.78	6.57	7.23
	R (ph-ph) (Ohms)	0.12	0.10		0.34	0.24	0.18
	L (ph-ph) (mH)	1.90	1.57		5.33	3.79	3.07
Connector Type		J*			B		

*Some frames have a 1.5 size power connector option "J".

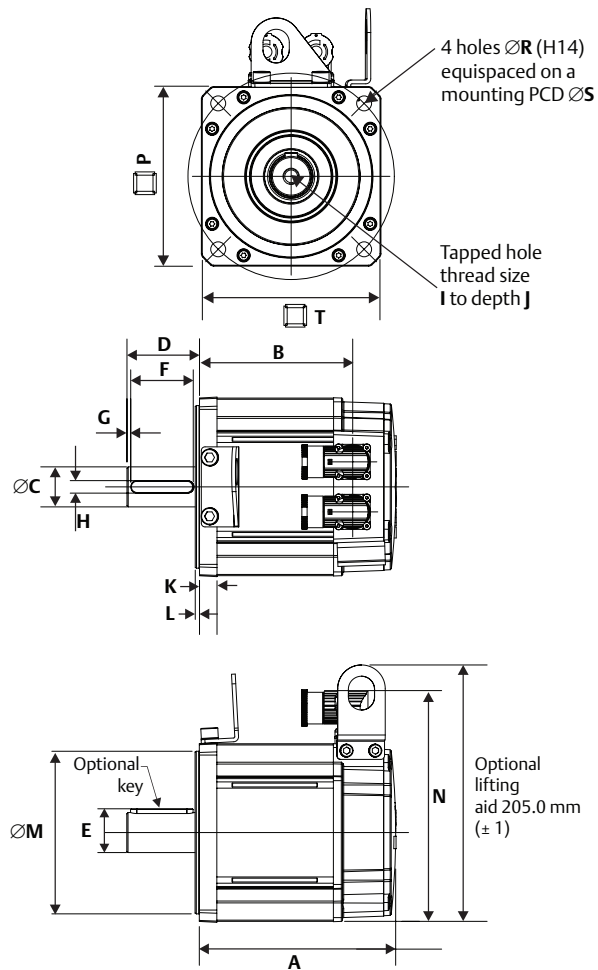

Motor Dimensions	Frame Length						
	C		D		E		
	(in)	(mm)	(in)	(mm)	(in)	(mm)	
Unbraked Length	A	8.54	217.0	9.72	247.0	10.91	277.0
	B	7.19	182.5	8.37	212.5	9.55	242.5
Braked Length	A	11.12	282.5	12.30	312.5	13.48	342.5
	B	9.76	248.0	10.94	278.0	12.13	308.0
Flange Dimensions		(in)		(mm)			
Flange Thickness	K	0.551		14.00			
Pilot Thickness	L	0.134		3.40			
Pilot Diameter	M	5.120		130.0			
Overall Height	N	4.1/8.1*		104/205*			
Flange Square	P	5.591		142.0			
Mounting Hole Dia.	R	0.472		12.0			
Mounting Hole BCD	S	6.500		165.0			
Motor Housing	T	5.591		142.0			
Mounting Bolts	M10						
Shaft Dimensions		(in)		(mm)			
Shaft Diameter	C	1.260		32.0			
Shaft Length	D	2.283		58.0			
Key Height	E	1.380		35.0			
Key Length	F	1.970		50.0			
Key-to-Shaft End	G	0.118		3.0			
Key Width	H	0.394		10.0			
Tapped Hole Thread Size	I	M12 x 1.75					
Tapped Hole Depth	J	1.142		29.0			

UNIMOTOR HD

Unimotor hd 190 mm Frame Ratings and Dimensions

Motor Frame Size (mm)	190ED			190UD		
	230			460		
Voltage (Vrms)						
Frame Length	C	D	F	C	D	F
Continuous Stall Torque (lb-in)	460.2	548.7	752.3	460.2	548.7	752.3
Continuous Stall Torque (Nm)	52.0	62.0	85.0	52.0	62.0	85.0
Peak Torque (lb-in)	1380.7	1646.2	2256.9	1380.7	1646.2	2256.9
Peak Torque (Nm)	156.0	186.0	255.0	156.0	186.0	255.0
Inertia (lb-in-sec ²)	.04833	.06275	.09161	.04833	.06275	.09161
Inertia (kgm ²)	.00546	.00709	.0103	.00546	.00709	.0103
Motor Weight (lb)	51.8	66.1	85.5	51.8	66.1	85.5
Motor Weight (kg)	23.5	28.6	38.8	23.5	28.6	38.6
Number of Poles	10	10	10	10	10	10
1000 rpm	Kt (lb-in/A) =		24.78			
	Kt (Nm/A) =		2.8			
	Ke (V/k rpm) =		171.0			
1500 rpm	Rated Torque (lb-in)	433.7	500.1	685.9		
	Rated Torque (Nm)	49.0	56.5	77.5		
	Stall Current (A)	18.6	22.1	30.4		
	Rated Power (hp)	6.88	7.94	10.89		
	Rated Power (kW)	5.13	5.92	8.12		
	R (ph-ph) (Ohms)	0.47	0.4	0.23		
	L (ph-ph) (mH)	12.3	10.4	6.79		
	Kt (lb-in/A) =		28.32			
	Kt (Nm/A) =		3.2			
	Ke (V/k rpm) =		196.0			
2000 rpm	Rated Torque (lb-in)	408.9	462.0	606.3		
	Rated Torque (Nm)	46.2	52.2	68.5		
	Stall Current (A)	16.3	19.4	26.6		
	Rated Power (hp)	9.74	11.00	14.43		
	Rated Power (kW)	7.26	8.2	10.76		
	R (ph-ph) (Ohms)	0.47	0.4	0.23		
	L (ph-ph) (mH)	12.3	10.4	6.79		
	Kt (lb-in/A) =		12.39			
	Kt (Nm/A) =		1.4			
	Ke (V/k rpm) =		85.5			
Rated Torque (lb-in)	376.2	376.2				
Rated Torque (Nm)	42.5	42.5				
Stall Current (A)	37.1	21.7				
Rated Power (hp)	11.9	11.9				
Rated Power (kW)	8.9	8.9				
R (ph-ph) (Ohms)	0.12	0.34				
L (ph-ph) (mH)	3.07	8.2				

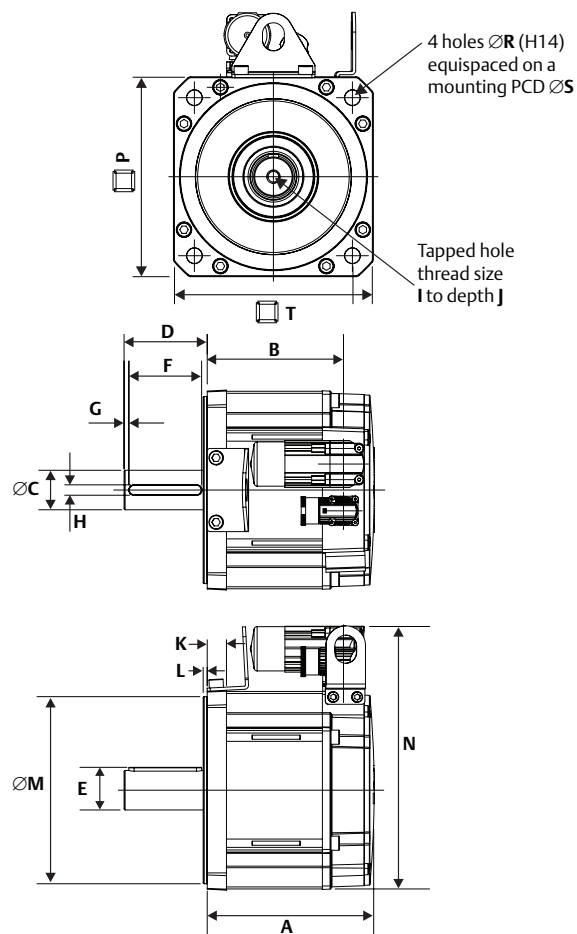

Motor Dimensions	Frame Length				
		C	D	E	
		(in)	(mm)	(in)	(mm)
Unbraked Length	A	8.69	220.6	9.87	250.6
	B	7.52	191.1	8.70	221.1
Braked Length	A	12.56	319.1	13.74	349.1
	B	11.40	289.6	12.58	319.6
Flange Dimensions		(in)		(mm)	
Flange Thickness	K	0.728		18.5	
Pilot Thickness	L	0.154		3.9	
Pilot Diameter	M	7.090		180.0	
Overall Height	N	9.940		252.5	
Flange Square	P	7.490		190.3	
Mounting Hole Diameter	R	0.571		14.5	
Mounting Hole BCD	S	8.465		215.0	
Motor Housing	T	7.480		190.0	
Mounting Bolts		M12			
Shaft Dimensions		(in)		(mm)	
Shaft Diameter	C	1.500		38.0	
Shaft Length	D	3.150		80.0	
Key Height	E	1.614		41.0	
Key Length	F	2.760		70.0	
Key-to-Shaft End	G	0.181		4.6	
Key Width	H	0.394		10.0	
Tapped Hole Thread Size	I	M12 x 1.75			
Tapped Hole Depth	J	1.142		29.0	

NOTES:

- $\Delta t = 212^\circ\text{F}$ (100°C) winding 104°F (40°C) maximum ambient; all data subject to +/-10% tolerance
- Stall torque, rated torque and power relate to maximum continuous operation tested in a 68°F (20°C) ambient above 12 kHz drive switching frequency
- Maximum intermittent winding temperature is 284°F (140°C)

Unimotor hd Selection Considerations

Feedback Options

Feedback Device Order Code	Feedback Type	Encoder Supply Voltage	SinCos Cycles or Incremental Pulses per Revolution	Resolution Available to Position Loop	Feedback Accuracy
055-067 Motors					
AR	Resolver ¹	7 Vrms	1	Medium	Low
		Excitation 5 kHz		16384 (14 bit)	+/- 600 arc second
CR	Incremental encoder	5 Vdc	4096	Medium	Medium
				16384 (14 bit)	+/- 150 arc second
EM (Multi-Turn) FM (Single-Turn)	Inductive Absolute encoder EnDat ²	5 Vdc	16	High	Medium
				2.62 x 10 ⁵ (18 bits)	+/- 480 arc second
089, 115, 142 and 190 Motors					
AE	Resolver ¹	6 Vrms	1	Medium	Medium
		Excitation 6 kHz		16384 (14 bit)	+/- 720 arc second
CA	Incremental encoder	5 Vdc	4096	Medium	High
				16384 (14 bit)	+/- 60 arc second
EC (Multi-Turn) FC (Single-Turn)	Inductive Absolute encoder EnDat ²	7 - 10 Vdc	32	Medium absolute position 524288 (19 bits)	Medium
				Very high	+/- 280 arc second
RA (Multi-Turn) SA (Single-Turn)	Optical SinCos encoder ² HIPERFACE	7 - 12 Vdc	1024	1.04 x 10 ⁶ (20 bits)	For SinCos integral non-linearity +/- 45 arc second For SinCos differential non-linearity +/- 7 arc second (total accuracy +/- 52 arc second)
				Very high	Very high
EB (Multi-Turn) FB (Single-Turn)	Optical Absolute encoder EnDat ²	3.6 - 14 Vdc	2048	Very high	Very high
				2.08 x 10 ⁶ (21 bits)	+/- 20 arc second (differential non-linearity +/- 1% signal period)

NOTES:

¹Resolution value shown when used with the Unidrive M resolver input or SM-Resolver Option Module (Unidrive Sp and Digitax ST)

²Resolution value shown when used with the Unidrive M, Unidrive SP or Digitax ST when the encoder type is set to either SC EnDat or SC Hiper, depending on the encoder - multi-turn devices have 4096 (12 bit) resolution

Motor Selection

Motor Derating

Adverse operating conditions require that the motor performance be derated. These conditions include ambient temperature above 104 °F (40 °C), motor mounting position, drive switching frequency or a drive oversized for the motor.

Ambient Temperatures

For ambient temperatures above 104 °F (40 °C), the torque must be derated using the following formula as a guideline for motors up to 3000 rpm. Consult factory for higher-speed motor derating information.

New derated torque =

$$\text{Specified torque} \times \sqrt{1 - \frac{[\text{ambient temperature}^* - 40]}{100}}$$

*Measured in °C

For example, with an ambient temperature of 169 °F (76 °C), the new derated torque will be 0.8 x specified torque.

Drive Switching Frequency

Most drive current ratings are reduced at higher switching frequencies. See individual drive manuals for details.

See the table below for motor derating factors (these figures are for guidance only).

Switching Frequency	Motor Type/Frame					
	055	067	089	115	142	190
3 kHz	0.92	0.93	0.89	0.89	0.83	0.90
4 kHz	0.93	0.94	0.91	0.92	0.85	0.95
5/6 kHz	0.95	0.95	0.95	0.96	0.88	1
8 kHz	0.96	0.98	0.97	0.98	0.91	1
10/12/16 kHz	1	1	1	1	1	1

Mounting Arrangements

In general, motor torque should be derated if the motor mounting surface is heated from an external source such as a gearbox, the motor is connected to a poor thermal conductor, or the motor is mounted in a confined space with restricted air flow.

Thermal Test Conditions

The performance data shown was recorded with an ambient temperature of 68 °F (20 °C) and the motor mounted on a thermally-isolated aluminum plate.

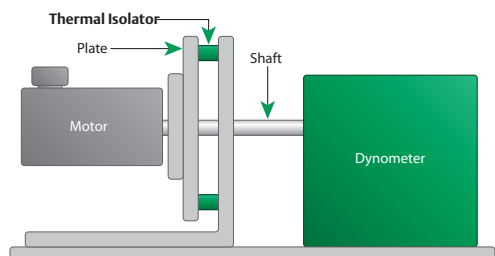

Motor Type/Frame	Aluminum Heatsink Plate	
	(in)	(mm)
055	4.3 x 4.3 x 1.06	110 x 110 x 27
067, 089	9.8 x 9.8 x 0.6	250 x 250 x 15
115 to 142	13.8 x 13.8 x 0.8	350 x 350 x 20
190	19.7 x 19.7 x 0.8	500 x 500 x 20

Thermal Protection

Thermistor protection to 293 °F (145 °C) is built into the motor windings and gives an indication of serious overheating problems. **The installer must connect the thermistor to the drive. Failure to do so will invalidate the motor warranty if winding burns out.**

Environmental Conditions

Any liquids or gases that may come into contact with the motor must be confirmed to ensure compliance with the correct international standards.

Brake Operation

Do not apply the brake while the motor shaft is rotating. The brake can only take a limited number of emergency braking operations and must not be used for repeated dynamic braking.

Ingress Protection

IP65 conformance; sealed against water spray and dust when mounted and connected.

Unimotor hd Holding Brake Specifications

Motor Frame Size (mm)	Power Supply (Vdc)	Power (W)	Static Torque		Release Time (ms) nom.	Added Inertia		Backlash Degrees*	Added Weight	
			(lb-in)	(Nm)		(lb-in-sec ²)	(kgcm ²)		(lbs)	(kg)
055	24	6.3	15.9	1.8	22	0.00003	0.03	0.73	0.88	0.4
067	24	10.2	35.4	4	<50	0.00006	0.073	0.75	1.1	0.5
089	24	23.4	88.5	10	<50	0.00010	0.115	0.75	1.3	0.6
115	24	19.5	117	20	120	0.00029	0.327	0.75	2.6	1.2
142	24	25	371	42	95	0.00225	2.54	0.77	6.2	2.8
190 C-D	24	25	592	67	120	0.00404	4.57	0.77	11.7	5.3
190 F	24	54.5	885	100	CF	0.00683	7.72	0.75	11.7	5.3

NOTES:

- Figures shown in individual motor sections are at 68 °F (20 °C) ambient
- Apply a derate factor of 0.7 to standard brake torque figures if motor temperature is above 212 °F (100 °C)
- *Backlash will increase over time



NT Motor 230 V

Compact NEMA or Metric Flange AC Servo Motors

The NT motor is a compact, high performance motor designed to maximize torque and minimize size. The NT motor uses powerful magnets and is manufactured with a segmented core to maximize stator efficiency.

NT motors are available with direct motor-to-drive connector terminations for Control Techniques' brand Unidrive M, Digitax ST and Epsilon EP servo drives – cable lengths up to 20 ft are available.

Key Features

- Torque range: 7.5 to 56 lb-in (0.85 to 6.3 Nm)
- Very low inertia for high acceleration and cycle rates
- English (NEMA 23 or 34) or Metric (IEC- 72-1) flanges
- Available with or without holding brakes
- Direct connect available – no additional cables required!
- Flying-lead cabling option (ex: NTE-320-LONS-0005) with improved ingress protection; flying leads are available with or without MS connectors
- IP65 conformance (IP67S and IP68S optional)
- Standard 2048 encoder
- Installed shaft seal are standard with all motors
- Optional white epoxy food-grade finish

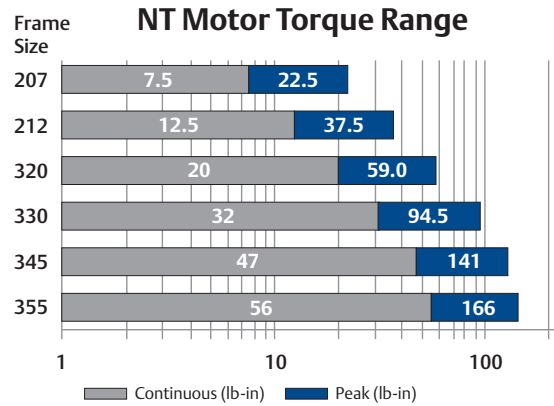

NT Motor 230 V Order Information

Use the information below to create an order code for an NT Motor (top row is an example).

NT	E	2	07	T	B	N	S	DP	10
Motor	Mounting Flange	Frame Size (in)	Rated Torque (lb-in)	Lead Configuration	Brake (24 V)	Feedback Device	Inertia	Feedback Cable Connectors / Optional Finish	Cable Length
NT	E = English M = Metric	2 = 2 [‡] 3 = 3 [‡]	2-in frame 07 = 7.5 12 = 12.5 3-in frame 20 = 20 30 = 32 45 = 47 55 = 56	IP65 C = MS connector L = Flying leads (no connectors) T = MS style connector on flying leads IP67S E = 90° circular Euro style IP68S F = Flying lead and white epoxy food-grade finish	O = Unbraked B = Holding Brake	N = Incremental encoder 2048 ppr	S = Low	Lead Configuration C, L, T, E 00 = Std. configuration Lead Configuration T DP = Flying lead with molded 15-pin feedback connector to Digitax ST, Unidrive SP and Epsilon EP Lead Configurations C, L, T, E, F E0 = White epoxy food-grade finish applied to standard motor*	Lead Configuration C, L, T, E 00 = Std. configuration Lead Config L, T And F 05 = 5-ft leads 10 = 10-ft leads 15 = 15-ft leads 20 = 20-ft leads XX = Custom lengths available up to 20 ft max. in 2-ft increments

*Include this code when ordering "F" type lead configuration

NOTES:
‡2 = 2-in NEMA 23
‡3 = 3-in NEMA 34

Approvals



NT Motor 2-inch Frame Ratings and Dimensions

Motor Frame Size (in)	2		
Voltage (Vrms)	230		
Model	NT-207	NT-212	
Continuous Stall Torque (lb-in)	7.5	12.5	
Continuous Stall Torque (Nm)	0.85	1.4	
Peak Torque (lb-in)	22.5	37.5	
Peak Torque (Nm)	2.54	4.24	
Inertia (lb-in-sec ²)	0.000094	0.000164	
Inertia (kgm ²)	0.0000106	0.0000185	
Cogging (lb-in) (typ.)	0.094	0.12	
Cogging (Nm) (typ.)	0.011	0.014	
Motor Weight (lbs)	3.0	4.0	
Motor Weight (kg)	1.36	1.81	
5000 rpm	Kt (lb-in/A) =	5.12	5.08
	Kt (Nm/A) =	0.58	0.57
	Ke (V/k rpm) =	35	34.7
Rated Torque (lb-in)	7.50	12.50	
Rated Torque (Nm)	0.85	1.4	
Stall Current (A)	1.7	2.7	
Rated Power (kW)	0.432	0.740	
R (ph-ph) (Ohms)	11.1	4.56	
L (ph-ph) (mH)	39.1	18.9	

- NOTES:
- Δt= 212 °F (100 °C) winding 104 °F (40 °C) maximum ambient; all data subject to +/-10% tolerance
 - Stall torque, rated torque and power relate to maximum continuous operation above 10 kHz drive switching frequency
 - Maximum intermittent winding temperature is 284 °F (140 °C)

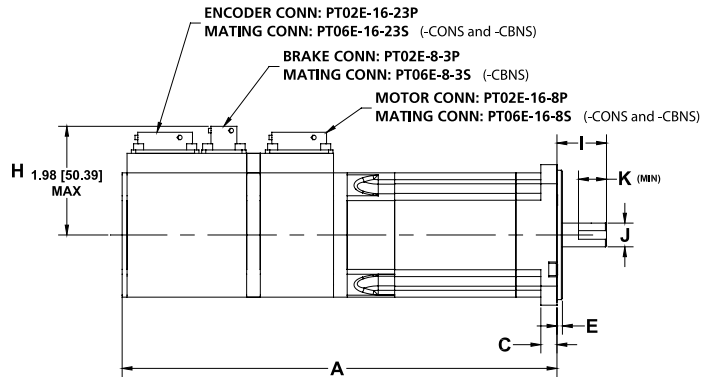
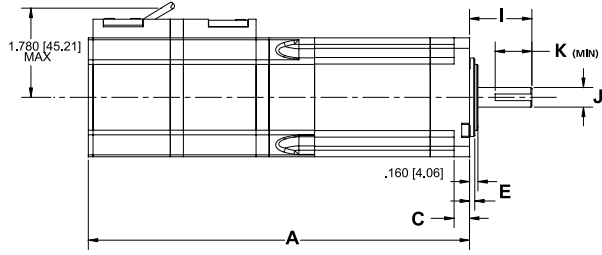
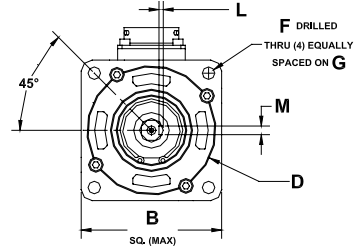

NT MOTORS

Motor Dimensions	English Flange				Metric Flange				
	NTE-207		NTE-212		NTM-207		NTM-212		
	(in)	(mm)	(in)	(mm)	(in)	(mm)	(in)	(mm)	
Unbraked Length — CONS/EONS*	5.55	141.0	6.55	166.4	5.55	141.0	6.55	166.4	
Braked Length — TONS/LONS/FONS	4.39	111.5	5.39	136.9	4.39	111.5	5.39	136.9	
Unbraked Length — CBNS/EBNS*	6.94	176.4	7.94	201.8	6.94	176.4	7.94	201.8	
Braked Length — TBNS/LBNS/FBNS	6.28	159.4	7.94	201.8	6.28	159.4	7.28	184.8	
Flange Square	B	2.27	57.7	2.27	57.7	2.57	65.2	2.57	65.2
Flange Thickness	C	0.29	7.5	0.29	7.5	0.29	7.5	0.29	7.5
Pilot Diameter	D	1.50	38.1	1.50	38.1	2.36	60.0	2.36	60.0
Pilot Thickness	E	0.10	2.5	0.10	2.5	0.10	2.5	0.10	2.5
Bolt Hole Diameter	F	0.21	5.2	0.21	5.2	0.23	5.8	0.23	5.8
Bolt Circle Diameter	G	2.63	66.7	2.63	66.7	2.95	75.0	2.95	75.0
Connector Height — CONS	H	1.92	48.9	1.92	48.9	1.92	48.9	1.92	48.9
Connector Height — TONS/LONS		1.78	45.2	1.78	45.2	1.78	45.2	1.78	45.2
Connector Height — CBNS		1.98	50.4	1.98	50.4	1.98	50.4	1.98	50.4
Connector Height — TBNS/LBNS		1.78	45.2	1.78	45.2	1.78	45.2	1.78	45.2
Shaft Length	I	1.21	30.7	1.21	30.7	0.93	23.5	0.93	23.5
Shaft Diameter	J	0.37	9.5	0.37	9.5	0.43	11.0	0.43	11.0
Shaft Key Dimensions					Shaft Key Dimensions				
Keyway Length (min)	K	0.70	17.8	0.70	17.8	0.51	13.0	0.51	13.0
Keyway Depth	L	0.08	2.0	0.08	2.0	0.08	2.1	0.08	2.1
Keyway Width	M	0.13	3.2	0.13	3.2	0.16	4.0	0.16	4.0

NOTE:
*Not all variations are represented above; see our website for complete mechanical dimension drawings

NT Motor 3-inch Frame Ratings and Dimensions

Motor Frame Size (in)	3				
Voltage (Vrms)	230				
Model	NT-320	NT-330	NT-345	NT-355	
Continuous Stall Torque (lb-in)	19.7	31.5	47.5	55.5	
Continuous Stall Torque (Nm)	2.2	3.56	5.31	6.27	
Inertia (lb-in-sec ²)	0.000328	0.000438	0.000668	0.000888	
Inertia (kgm ²)	0.000037	0.000049	0.000075	0.000100	
Peak Torque (lb-in)	59.0	94.5	141.0	166.0	
Peak Torque (Nm)	6.67	10.68	15.93	18.75	
Cogging (lb-in) (typ.)	0.18	0.315	0.47	0.555	
Cogging (Nm) (typ.)	0.020	0.036	0.053	0.063	
Motor Weight (lbs)	6.0	7.3	10.0	12.3	
Motor Weight (kg)	2.72	3.31	4.54	5.58	
3000 rpm	Kt (lb-in/A) =		7.13	7.30	
	Kt (Nm/A) =		0.806	0.825	
	Ke (V/k rpm) =		50.0	50.0	
Rated Torque (lb-in)			47.0	55.5	
Rated Torque (Nm)			5.31	6.27	
Stall Current (A)			6.59	7.6	
Rated Power (kW)			1.668	1.97	
R (ph-ph) (Ohms)			1.3	1.0	
L (ph-ph) (mH)			17.0	13.0	
4000 rpm	Kt (lb-in) =	3.50	5.04		
	Kt (Nm/A) =	0.40	0.569		
	Ke (V/k rpm) =	29.0	36.0		
	Rated Torque (lb-in)	16.0	31.6		
	Rated Torque (Nm)	1.8	3.56		
	Stall Current (A)	5.4	6.25		
	Rated Power (kW)	0.757	1.49		
	L (ph-ph) (mH)	16.0	15.0		

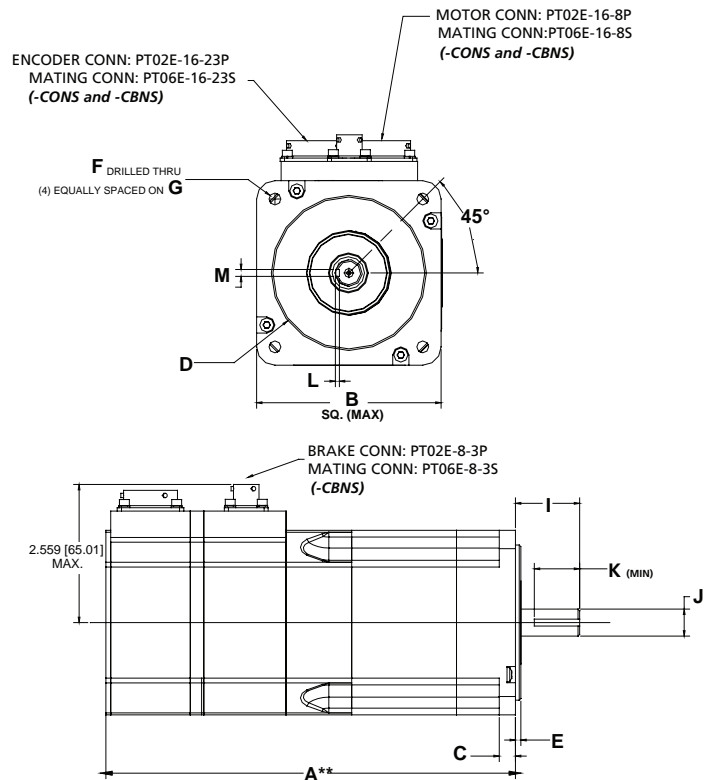

NOTES:

- $\Delta t = 212^\circ\text{F}$ (100°C) winding 104°F (40°C) maximum ambient; all data subject to +/-10% tolerance
- Stall torque, rated torque and power relate to maximum continuous operation above 10 kHz drive switching frequency
- Max. intermittent winding temperature is 284°F (140°C)

Motor Dimensions	English Flange								Metric Flange							
	NTE-320		NTE-330		NTE-345		NTE-355		NTM-320		NTM-330		NTM-345		NTM-355	
	(in)	(mm)	(in)	(mm)	(in)	(mm)	(in)	(mm)	(in)	(mm)	(in)	(mm)	(in)	(mm)	(in)	(mm)
Unbraked Length — CONS/EONS*	5.22	132.5	5.82	147.8	7.02	178.3	9.42	239.2	5.22	132.5	5.82	147.8	7.02	178.3	9.42	239.2
Braked Length — TONS/LONS/FONS	5.22	132.5	5.82	147.8	7.02	178.3	9.43	239.6	5.22	132.5	5.82	147.8	7.02	178.3	9.43	239.6
Unbraked Length — CBNS/EBNS*	7.24	184.0	7.84	199.2	9.04	229.7	11.44	290.7	7.24	184.0	7.84	199.2	9.04	229.7	11.44	290.7
Braked Length — TBNS/LBNS/FBNS	7.24	184.0	7.84	199.2	9.04	229.7	11.44	290.7	7.24	184.0	7.84	199.2	9.04	229.7	11.44	290.7
Flange Square	3.42	86.9	3.42	86.9	3.42	86.9	3.42	86.9	3.42	86.9	3.42	86.9	3.42	86.9	3.42	86.9
Flange Thickness	0.30	7.6	0.30	7.6	0.30	7.6	0.30	7.6	0.30	7.6	0.30	7.6	0.30	7.6	0.30	7.6
Pilot Diameter	2.88	73.0	2.88	73.0	2.88	73.0	2.88	73.0	3.15	80.0	3.15	80.0	3.15	80.0	3.15	80.0
Pilot Thickness	0.10	2.5	0.10	2.5	0.10	2.5	0.10	2.5	0.12	3.0	0.12	3.0	0.12	3.0	0.12	3.0
Bolt Hole Diameter	0.22	5.6	0.22	5.6	0.22	5.6	0.22	5.6	0.28	7.0	0.28	7.0	0.28	7.0	0.28	7.0
Bolt Circle Diameter	3.88	98.4	3.88	98.4	3.88	98.4	3.88	98.4	3.94	100.0	3.94	100.0	3.94	100.0	3.94	100.0
Connector Height — CONS	2.45	62.2	2.45	62.2	2.45	62.2	2.45	62.2	2.45	62.2	2.45	62.2	2.45	62.2	2.45	62.2
Connector Height — TONS/LONS	2.35	59.7	2.35	59.7	2.35	59.7	2.35	59.7	2.35	59.7	2.35	59.7	2.35	59.7	2.35	59.7
Connector Height — CBNS	2.56	65.0	2.56	65.0	2.56	65.0	2.56	65.0	2.56	65.0	2.56	65.0	2.56	65.0	2.56	65.0
Connector Height — TBNS/LBNS	2.50	63.5	2.50	63.5	2.50	63.5	2.50	63.5	2.50	63.5	2.50	63.5	2.50	63.5	2.50	63.5
Shaft Length	1.21	30.7	1.21	30.7	1.21	30.7	1.21	30.7	1.21	30.7	1.21	30.7	1.21	30.7	1.21	30.7
Shaft Diameter	0.50	12.7	0.50	12.7	0.50	12.7	0.50	12.7	0.55	14.0	0.55	14.0	0.55	14.0	0.55	14.0
Shaft Key Dimensions								Shaft Key Dimensions								
Keyway Length (min)	0.84	21.3	0.84	21.3	0.84	21.3	0.84	21.3	0.79	20.0	0.79	20.0	0.79	20.0	0.79	20.0
Keyway Depth	0.08	2.0	0.08	2.0	0.08	2.0	0.08	2.0	0.10	2.6	0.10	2.6	0.10	2.6	0.10	2.6
Keyway Width	0.13	3.2	0.13	3.2	0.13	3.2	0.13	3.2	0.20	5.1	0.20	5.1	0.20	5.1	0.20	5.1

NOTE:

*Not all variations are represented above; see our website for complete mechanical dimension drawings

NT Motor Flying Lead and Connector Details

LBNS, LONS

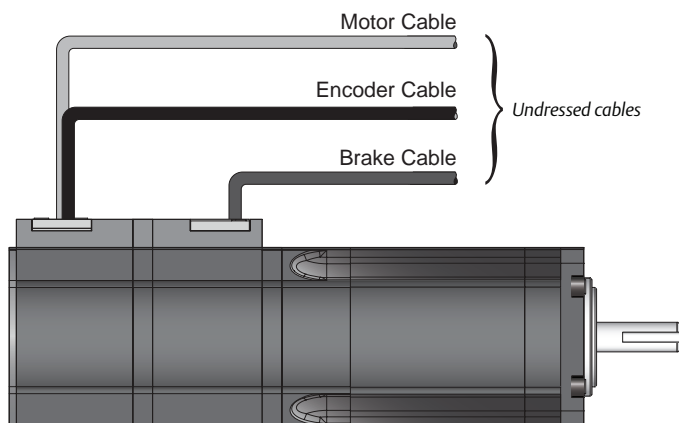

TBNS, TONS

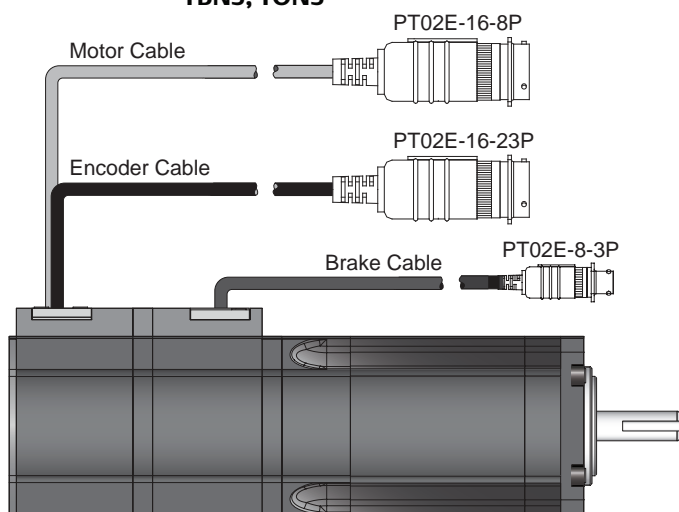

TBNS-DP, TONS-DP

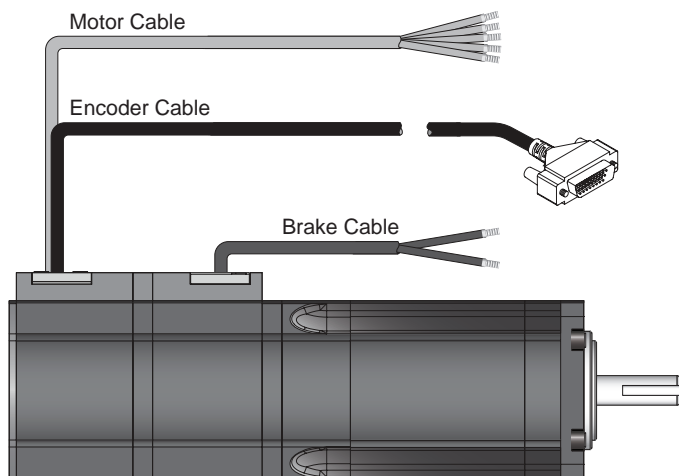

NOTE:

DP models include connector terminations specifically for Unidrive M, Unidrive SP, Epsilon EP and Digitax ST (DP-15)

NT Motor Flying Lead and Connector Details

FBNS, FONS

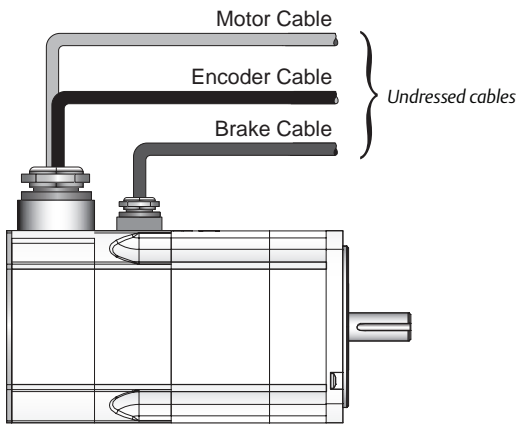

EBNS, EONS

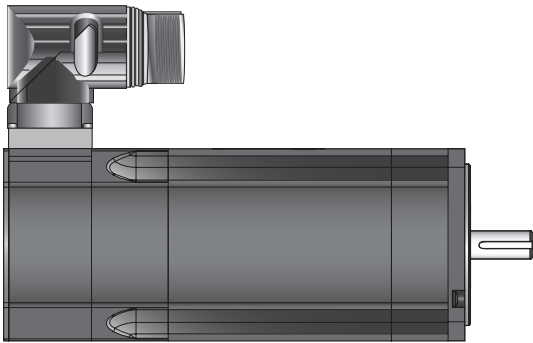

CBNS, CONS

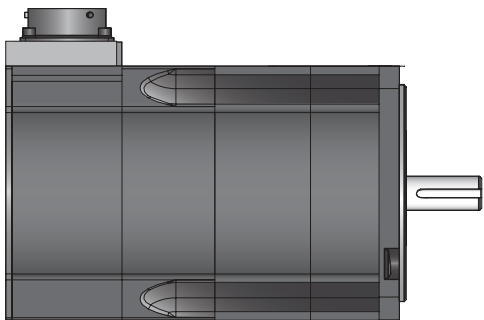

NT Motor Selection Considerations

Feedback Options

Feedback Device Order Code	Feedback Type	Encoder Supply Voltage	SinCos or Incremental Pulses per Revolution	Resolution Available to Position Loop	Feedback Accuracy
-T_NS, -C_NS, -L_NS, -E_NS, -F_NS	Incremental Encoder	5 Vdc	2048	16384 (14 bits)	±600 arc sec.

Motor Selection

Motor Derating

Any adverse operating conditions require that the motor performance be derated. These conditions include ambient temperature above 104 °F (40 °C), motor mounting position, drive switching frequency or a drive oversized for the motor.

Drive Switching Frequency

Most drive current ratings are reduced at higher switching frequencies. See individual drive manuals for details.

Mounting Arrangements

In general, motor torque should be derated if the motor mounting surface is heated from an external source such as a gearbox, the motor is connected to a poor thermal conductor, or the motor is mounted in a confined space with restricted air flow.

Thermal Test Conditions

The performance data shown was recorded with an ambient temperature of 68 °F (20 °C) and the motor mounted on a thermally-isolated aluminum plate.

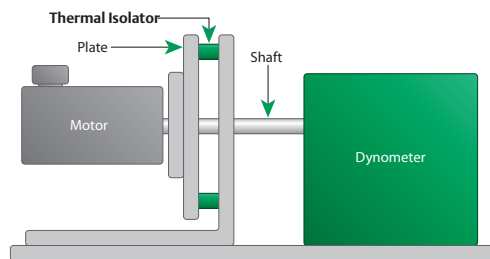

Motor Model	Frame Size	Mounting Plate Dimensions
NT	2"	6" x 6" x 1/4"
	3"	10" x 10" x 3/8"

NT Motor Holding Brake Specifications

Motor Frame Size (in)	Power Supply (Vdc)	Current (A)	Static Torque (lb-in) (Nm)	Mechanical Release Time (ms)	Mechanical Engagement Time (ms)	Added Inertia (lb-in-sec ²) (kgm ²)
2	24	0.33	20.0 2.26	28.0	14.0	0.000106 0.000012
3	24	0.65	88.5 10.0	43.0	13.0	0.000968 0.000109

Brake Operation

Do not apply the brake while the motor shaft is rotating. The brake can only take a limited number of emergency braking operations and must not be used for repeated dynamic braking.

Thermal Protection

Thermistor protection to 284 °F (140 °C) is built into the motor windings and gives an indication of serious overheating problems. **The installer must connect the thermistor to the drive. Failure to do so will invalidate the motor warranty if winding burns out.**

Environmental Conditions

Any liquids or gases that may come into contact with the motor must be confirmed to ensure compliance with the correct international standards.

Ingress Protection

All NT Motors have shaft seals installed as standard. Standard models have an ingress rating (IP rating) of IP65. Lead configuration "E" models are rated IP67S. Configuration "F" models are rated IP68S.

XV Motor 230 V

Economical Metric AC Servo Motor

The XV Motor is a high performance, low-inertia and high-torque servo motor in a compact economical package – ideal for high-volume applications. UL recognized, CE approved and RoHS compliant, XV Motors offer low-cost solutions with the features of a premium-priced servo offering.

Intended for higher throughputs and smaller machines, XV Motors are available in 4 frame sizes: 40, 60, 80 and 130 mm with speeds ranging from 2000 to 5000 rpm. Applications with continuous torque requirements up to 101 lb-in (11.4 Nm) are the perfect match for XV Motors.

XV Motors with 40, 60 and 80 mm are fitted with AMP (Tyco® Mate-n-Lock™) connectors on 1-ft flying leads. (For added strain relief, these connectors can be snapped into place through holes in panels or brackets.)



Key Features

- Torque range: 0.95 to 101 lb-in (0.1 to 11.4 Nm)
- Speed rating to 5000 rpm
- Four frame sizes: 40, 60, 80 and 130 mm
- UL recognized, CE approved and RoHS
- Ambient operating temperature: 32 to 122 °F (0 to 40 °C)

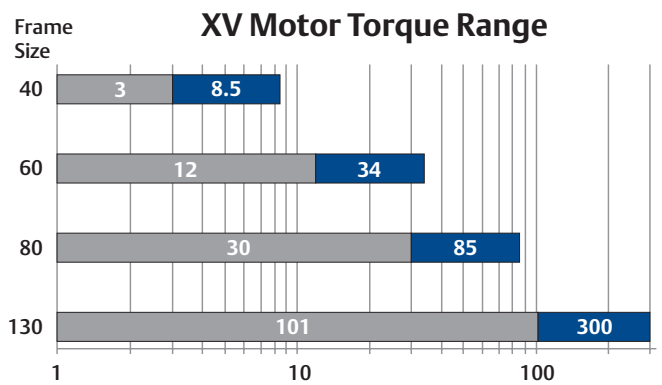

Order Code

XVM	60	4	T	B	N	S	0000
Motor	Frame Size (mm)	Torque	Connections	Brake	Feedback Device	Inertia	Specials
	Frame Order Code						
XVM	see table below for frame order code		C = MS connector	O = Unbraked	N = Incremental encoder 2048 ppr	S = Std.	Low voltage windings
230 V			T = AMP connector on flying leads (40-80 frame)	B = 24 V Holding Brake			

Frame Order Code	Stall Torque		Order Information	
	(in)	(mm)	Motor Only	Brake Motor
401	0.9	0.1	XVM-401-TONS-0000	XVM-401-TBNS-0000
402	1.4	0.16	XVM-402-TONS-0000	XVM-402-TBNS-0000
403	2.8	0.32	XVM-403-TONS-0000	XVM-403-TBNS-0000
604	2.8	0.32	XVM-604-TONS-0000	XVM-604-TBNS-0000
606	5.7	0.64	XVM-606-TONS-0000	XVM-606-TBNS-0000
6011	11.24	1.27	XVM-6011-TONS-0000	XVM-6011-TBNS-0000
8017	16.9	1.91	XVM-8017-TONS-0000	XVM-8017-TBNS-0000
8022	22.6	2.55	XVM-8022-TONS-0000	XVM-8022-TBNS-0000
8023	23.3	2.63	XVM-8023-TONS-0000	XVM-8023-TBNS-0000
8028	28.1	3.18	XVM-8028-TONS-0000	XVM-8028-TBNS-0000
13046	46.5	5.25	XVM-13046-CONS-0000	XVM-13046-CBNS-0000
13051	50.7	5.73	XVM-13051-CONS-0000	XVM-13051-CBNS-0000
13068	67.6	7.64	XVM-13068-CONS-0000	XVM-13068-CBNS-0000
13089	88.8	10.03	XVM-13089-CONS-0000	XVM-13089-CBNS-0000
130101	101.4	11.46	XVM-130101-CONS-0000	XVM-130101-CBNS-0000

Approvals



RoHS Compliant



XV Motor 40 mm Frame Ratings and Dimensions

Motor Frame Size (mm)	40			
Voltage (Vrms)	230			
Model	XVM-401	XVM-402	XVM-403	
Continuous Stall Torque (lb-in)	0.95	1.4	2.8	
Continuous Stall Torque (Nm)	0.11	0.16	0.32	
Peak Stall Torque (lb-in)	2.4	4.5	7.7	
Peak Stall Torque (Nm)	0.27	0.51	0.87	
Inertia (lb-in-sec ²)	0.00001	0.00002	0.00004	
Inertia (kgm ²)	0.000001	0.000002	0.000005	
Cogging (lb-in) (typ.)	0.02	0.03	0.06	
Cogging (Nm) (typ.)	0.002	0.003	0.007	
Weight Unbraked (lbs)	0.7	0.88	1.1	
Weight Unbraked (Kg)	0.32	0.40	0.50	
Rated Speed 3000 rpm	Kt (lb-in/A) =	0.89	1.24	2.8
Max. Speed 5000 rpm	Kt (Nm/A) =	0.101	0.140	0.32
	Ke (V/k rpm) =	7.8	10.6	12.7
	Rated Torque (lb-in)	0.95	1.4	3.09
	Rated Torque (Nm)	0.11	0.16	0.35
	Stall Current (A)	1.07	1.20	1.38
	Rated Power (kW)	0.034	0.050	0.110
	R (ph-ph) (Ohms)	11.69	9.4	6.89
	L (ph-ph) (mH)	8.54	8.27	6.73

NOTE:
 • The 40 mm-frame XV Motor has a 1-ft cable terminated with a Tyco Mate-n-Lock connector

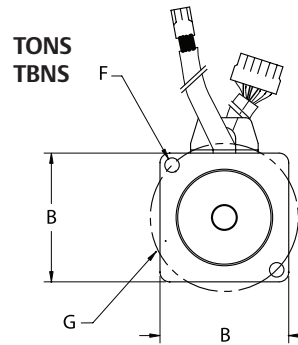

Flying lead length 1ft on 40mm, 60mm and 80mm

PLUG: AMP 172167-1 mating connector - Amp housing - 172159-1 pins - 170362-1
 PLUG: AMP 172165-1 mating connector - Amp housing - 172157-1 pins - 170362-1
 PLUG: AMP 172171-1 mating connector - Amp housing - 172163-1 pins - 170361-1

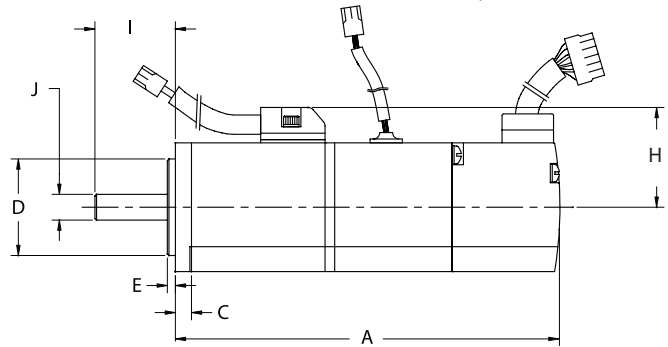

Dimensions		XVM-401		XVM-402		XVM-403	
		(in)	(mm)	(in)	(mm)	(in)	(mm)
Unbraked Length — TONS/LONS (max)	A	2.98	76.0	3.27	83.0	3.92	99.5
Braked Length — TBNS/LBNS (max)		4.41	112.0	4.72	120.0	5.35	136.0
Flange Square	B	1.57	40.0	1.57	40.0	1.57	40.0
Flange Thickness	C	0.20	5.0	0.20	5.0	0.20	5.0
Pilot Diameter	D	1.18	30.0	1.18	30.0	1.18	30.0
Pilot Thickness	E	0.10	2.5	0.10	2.5	0.10	2.5
Bolt Hole Diameter	F	0.18	4.5	0.18	4.5	0.18	4.5
Bolt Circle Diameter	G	1.81	46.0	1.81	46.0	1.81	46.0
Connector Height (max)	H	1.22	31.0	1.22	31.0	1.22	31.0
Connector Height (max)		1.22	31.0	1.22	31.0	1.22	31.0
Shaft Length	I	0.98	25.0	0.98	25.0	0.98	25.0
Shaft Diameter	J	0.31	8.0	0.31	8.0	0.31	8.0

NOTE:
 • All 40-mm frame XV Motors have smooth shafts

XV Motor 60/80 mm Frame Ratings and Dimensions

Motor Frame Size (mm)	60			80			
Voltage (Vrms)	230						
Model	XVM-604	XVM-606	XVM-6011	XVM-8017	XVM-8022	XVM-8023	XVM-8028
Continuous Stall Torque (lb-in)	2.81	5.7	11.2	16.9	22.6	23.3	28.1
Continuous Stall Torque (Nm)	0.32	0.64	1.27	1.91	2.55	2.72	3.18
Peak Stall Torque (lb-in)	8.45	16.1	32.3	48.6	62.7	67.1	81.1
Peak Stall Torque (Nm)	0.95	1.82	3.65	5.49	7.08	7.58	9.16
Inertia (lb-in-sec ²)	0.00010	0.00016	0.00028	0.00096	0.001335	0.001335	0.001705
Inertia (kgm ²)	0.000011	0.000018	0.000032	0.00011	0.00015	0.00015	0.00019
Cogging (lb-in) (typ.)	0.06	0.11	0.24	0.18	0.23	0.24	0.28
Cogging (Nm) (typ.)	0.006	0.013	0.027	0.020	0.026	0.027	0.032
Weight Unbraked (lbs)	1.85	2.4	3.5	5.4	6.94	6.9	8.37
Weight Unbraked (Kg)	0.84	1.09	1.59	2.45	3.15	3.14	3.80
Rated Speed 3000 rpm	Kt (lb-in/A) =					6.32	
Max. Speed 5000 rpm	Kt (Nm/A) =					0.714	
	Ke (V/k rpm) =					44.6	
Rated Torque (lb-in)						24.1	
Rated Torque (Nm)						2.72	
Stall Current (A)						3.82	
Rated Power (kW)						0.8556	
R (ph-ph) (Ohms)						1.29	
L (ph-ph) (mH)						9.1	
Rated Speed 3000 rpm	1.82	3.76	4.15	5.0	5.04	5.5	
Max. Speed 5000 rpm	0.206	0.425	0.469	0.565	0.569	0.621	
	12.43	29.3	29.5	35.2	35.6	39.2	
Rated Torque (lb-in)	2.81	6.13	12	17.9	22.6	28.1	
Rated Torque (Nm)	0.32	0.69	1.27	2.02	2.55	3.18	
Stall Current (A)	1.54	1.52	2.89	3.58	4.83	5.37	
Rated Power (kW)	0.100	0.218	0.426	0.635	0.802	0.998	
R (ph-ph) (Ohms)	2.49	4.15	1.64	1.43	0.87	0.75	
L (ph-ph) (mH)	7.37	15.21	7.32	9.2	5.9	5.04	

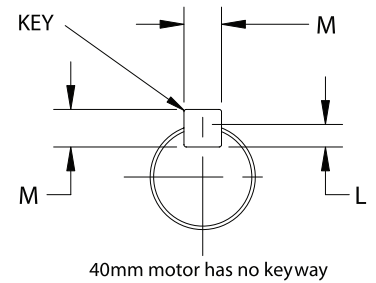

NOTE:

- The 60 mm and 80 mm-frame XV Motors have a 1-ft cable terminated with a Tyco Mate-n-Lock connector

Dimensions	XVM-604		XVM-606		XVM-6011		XVM-8017		XVM-8022 XVM-8023		XVM-8028		
	(in)	(mm)	(in)	(mm)	(in)	(mm)	(in)	(mm)	(in)	(mm)	(in)	(mm)	
Unbraked Length — TONS/LONS (max)	A	3.64	92.5	4.17	106.0	5.28	134.0	5.43	138.0	6.22	158.0	7.01	178.0
Braked Length — TBNS/LBNS (max)		5.14	130.0	5.75	146.0	6.85	174.0	7.01	178.0	7.80	198.0	8.58	218.0
Flange Square	B	2.44	62.0	2.44	62.0	2.44	62.0	3.15	80.0	3.15	80.0	3.15	80.0
Flange Thickness	C	0.24	6.0	0.24	6.0	0.24	6.0	0.43	11.0	0.43	11.0	0.43	11.0
Pilot Diameter	D	1.97	50.0	1.97	50.0	1.97	50.0	2.76	70.0	2.76	70.0	2.76	70.0
Pilot Thickness	E	0.12	3.0	0.12	3.0	0.12	3.0	0.12	3.0	0.12	3.0	0.12	3.00
Bolt Hole Diameter	F	0.24	6.0	0.24	6.0	0.24	6.0	0.26	6.60	0.26	6.6	0.26	6.60
Bolt Circle Diameter	G	2.76	70.0	2.76	70.0	2.76	70.0	3.54	90.0	3.54	90.0	3.54	90.0
Connector Height (max)	H	1.73	44.0	1.73	44.0	1.73	44.0	2.09	53.0	2.09	53.0	2.09	53.0
Connector Height (max)		1.73	44.0	1.73	44.0	1.73	44.0	2.09	53.0	2.09	53.0	2.09	53.0
Shaft Length	I	1.18	30.0	1.18	30.0	1.18	30.0	1.57	40.0	1.57	40.0	1.57	40.0
Shaft Diameter	J	0.55	14.0	0.55	14.0	0.55	14.0	0.63	16.0	0.63	16.0	0.63	16.0
Shaft Key Dimensions													
Keyway Length (min)	K	0.89	22.5	0.89	22.5	0.89	22.5	1.18	30.0	1.18	30.0	1.18	30.0
Keyway Depth	L	0.12	3.0	0.12	3.0	0.12	3.0	0.12	3.0	0.12	3.0	0.12	3.0
Keyway Width	M	0.197	5.0	0.197	5.0	0.197	5.0	0.197	5.0	0.197	5.0	0.197	5.0

XV Motor 130 mm Frame Ratings and Dimensions

Motor Frame Size (mm)	130				
Voltage (Vrms)	230				
Model	XVM-13046	XVM-13051	XVM-13068	XVM-13089	XVM-130101
Continuous Stall Torque (lb-in)	46.5	50.7	67.6	88.8	101.4
Continuous Stall Torque (Nm)	5.25	5.73	7.64	10.03	11.46
Peak Stall Torque (lb-in)	137	147.8	199.2	260.4	296.4
Peak Stall Torque (Nm)	15.48	16.70	22.51	29.42	33.49
Inertia (lb-in-sec ²)	0.01061	0.01061	0.01535	0.01535	0.02001
Inertia (kgm ²)	0.00120	0.00120	0.00173	0.00173	0.00226
Cogging (lb-in) (typ.)	0.47	0.51	0.68	0.89	1.01
Cogging (Nm) (typ.)	0.053	0.057	0.076	0.100	0.115
Weight Unbraked (lbs)	15.86	15.8	19.1	21.3	22.47
Weight Unbraked (Kg)	7.21	7.18	8.68	9.68	10.21
Rated Speed 3000 rpm	Kt (lb-in/A) = 12.57		13.45		13.6
Max. Speed 5000 rpm	Kt (Nm/A) = 1.420		1.520		1.537
	Ke (V/k rpm) = 85.8		94.6		89.96
Rated Torque (lb-in)	50.7		88.76		101.4
Rated Torque (Nm)	5.73		10.03		11.46
Stall Current (A)	4.15		6.75		7.63
Rated Power (kW)	0.600		1.050		1.200
R (ph-ph) (Ohms)	1.9		1.41		0.87
L (ph-ph) (mH)	20.1		15.99		10.67
Rated Speed 3000 rpm	Kt (lb-in/A) = 7.5		7.4		
Max. Speed 5000 rpm	Kt (Nm/A) = 0.847		0.836		
	Ke (V/k rpm) = 53.1		54.21		
Rated Torque (lb-in)	46.5		67.6		
Rated Torque (Nm)	5.25		7.64		
Stall Current (A)	6.28		9.23		
Rated Power (kW)	1.101		1.600		
R (ph-ph) (Ohms)	0.77		0.47		
L (ph-ph) (mH)	7.76		5.3		

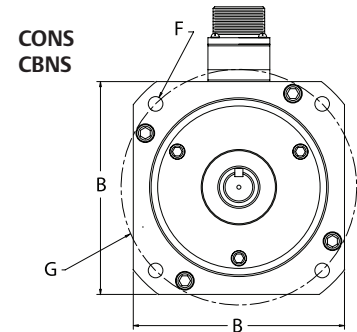

Connector standard: MS3102A20-4P
 Mating Connector: Amphenol MS3106A-20-4S
 Connector brake: MS3102A20-15P
 Mating Connector: Amphenol MS3106A-20-15S

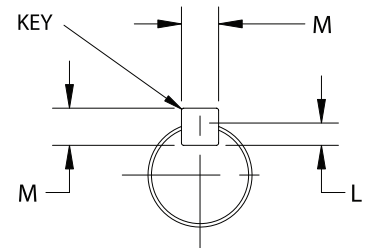
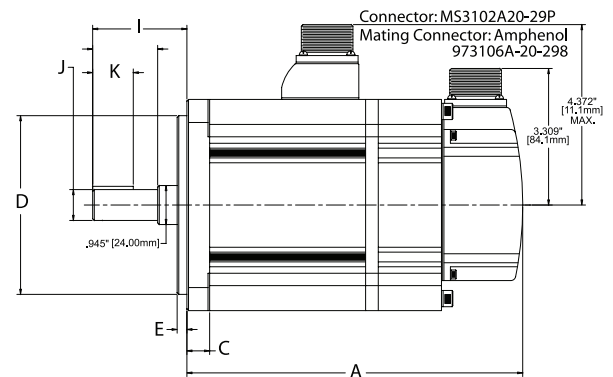

XV MOTORS

Dimensions	XVM-13046		XVM-13051		XVM-13068		XVM-13089		XVM-130101		
	(in)	(mm)	(in)	(mm)	(in)	(mm)	(in)	(mm)	(in)	(mm)	
Unbraked Length (max)	A	6.61	168.0	6.61	168.0	7.56	192.0	7.56	192.0	8.50	216.0
Braked Length (max)	A	8.11	206.0	8.11	206.0	9.06	230.0	9.06	230.0	10.0	254.0
Flange Square	B	5.12	130.0	5.12	130.0	5.12	130.0	5.12	130.0	5.12	130.0
Flange Thickness	C	0.55	14.0	0.55	14.0	0.55	14.0	0.55	14.0	0.55	14.0
Pilot Diameter	D	4.33	110.0	4.33	110.0	4.33	110.0	4.33	110.0	4.33	110.0
Pilot Thickness	E	0.24	6.0	0.24	6.0	0.24	6.0	0.24	6.0	0.24	6.0
Bolt Hole Diameter	F	0.35	9.0	0.35	9.0	0.35	9.0	0.35	9.0	0.35	9.0
Bolt Circle Diameter	G	5.71	145.0	5.71	145.0	5.71	145.0	5.71	145.0	5.71	145.0
Connector Ht — Unbraked (max)	H	4.41	112.0	4.41	112.0	4.41	112.0	4.41	112.0	4.41	112.0
Connector Ht — Braked (max)		4.41	112.0	4.41	112.0	4.41	112.0	4.41	112.0	4.41	112.0
Shaft Length	I	2.28	58.0	2.28	58.0	2.28	58.0	2.28	58.0	2.28	58.0
Shaft Diameter	J	0.75	19.0	0.75	19.0	0.87	22.0	0.87	22.0	0.87	22.0
Shaft Key Dimensions											
Keyway Length (min)	K	0.98	25.0	0.98	25.0	0.98	25.0	0.98	25.0	0.98	25.0
Keyway Depth	L	0.118	3.0	0.118	3.0	0.138	3.50	0.138	3.50	0.138	3.5
Keyway Width	M	0.197	5.0	0.197	5.0	0.236	6.0	0.236	6.0	0.236	6.0

XV Motor Selection Considerations

XV Motor Feedback – All Frame Sizes

XV Motors include a 5 Vdc incremental encoder with 2048 pulses per revolution.

Motor Selection

Motor Derating

Any adverse operating conditions require that the motor performance be derated. These conditions include ambient temperature above 104 °F (40 °C), motor mounting position, drive switching frequency or a drive oversized for the motor.

Ambient Temperatures

For ambient temperatures above 104 °F (40 °C), the torque must be derated.

Mounting Arrangements

In general, motor torque should be derated if the motor mounting surface is heated from an external source such as a gearbox, the motor is connected to a poor thermal conductor, or the motor is mounted in a confined space with restricted air flow.

Drive Switching Frequency

Most drive current ratings are reduced at higher switching frequencies. See individual drive manuals for details.

Thermal Test Conditions

The performance data shown was recorded with an ambient temperature of 68 °F (20 °C) and the motor mounted on a thermally-isolated aluminum plate.

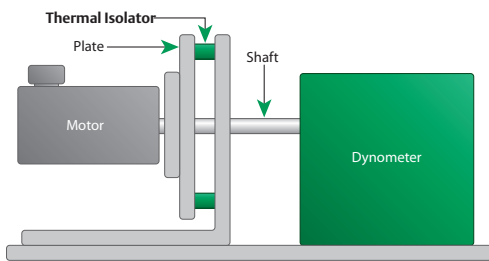

Motor Frame (mm)	Aluminum Heatsink Plate	
	(in)	(mm)
40	5.91 x 5.91 x 0.24	150 x 150 x 6
60	5.91 x 5.91 x 0.24	150 x 150 x 6
80	9.84 x 9.84 x 0.39	250 x 250 x 10
130	9.84 x 9.84 x 0.39	250 x 250 x 10

Thermal Protection

The XV Motors do not have and are not offered with a winding thermal temperature sensor. Motor feedback cables have the Motor Temperature Sensor lines defeated (shorted between pin 14 (GND) and pin 15 (5 V)). These cables include cable model numbers XUFTS-xxx and XUFCS-xxx (where -xxx is cable length in feet).

All Control Techniques' brand servo drives have a current-limiting algorithm in the firmware specifically to limit current levels. When properly matched and limited to the motor specifications, the drive firmware will fault the drive when the rated rms current of the motor is exceeded.

Environmental Conditions

Any liquids or gases that may come into contact with the motor must be confirmed to ensure compliance with the correct international standards.

Ingress Protection

Standard models have an ingress rating (IP rating) as listed in the table below.

Frame Size	IP rating	Exclusions
40 mm	IP55*	Shaft through area of face plate and connectors
60 mm	IP55*	Shaft through area of face plate and connectors
80 mm	IP65*	Shaft through area of face plate and connectors
130 mm	IP65*	Shaft through area of face plate

NOTE:

* Shaft seal option is not available

Brake Operation

Do not apply the brake while the motor shaft is rotating. The brake can only take a limited number of emergency braking operations and must not be used for repeated dynamic braking.

XV Motor Holding Brake Specifications

Motor Frame Size (mm)	Power Supply (Vdc)	Current (A)	Static Torque		Mechanical Engagement Time (ms)	Added Inertia		Added Weight (kg)
			(lb-in)	(Nm)		(lb-in-sec ²)	(kg·m ² x 10 ⁻³)	
40	24	0.25	2.8	0.318	20	0.000023	0.003	0.2
60	24	0.27	13.0	1.47	50	0.000045	0.048	0.6
80	24	0.38	28.6	3.23	60	0.00011	0.125	0.7
130	24	0.29	70.8	8	40	0.000478	0.54	0.83

NOTES:

- Figures shown in individual motor sections are at 68 °F (20 °C) ambient
- Apply a derate factor of 0.7 to standard brake torque figures if motor temperature is above 212 °F (100 °C)

Cables for Servo Motors

Servo Motor Cables

Cables are a vital part of a servo motor installation. Using Emerson's comprehensive range of high quality cables and connector options, installers can avoid the time and risks involved in manufacturing custom assemblies.

The matched power and feedback cables provide rapid worry-free installation. Control Techniques' brand servo motor-to-drive cables meet EMC standards to ensure a system free from unwanted noise and interference.

Each power cable has drive terminations that make it convenient to connect to the specific drive used.

Cables are available for braked and unbraked motors in standard or flexible duty formats.

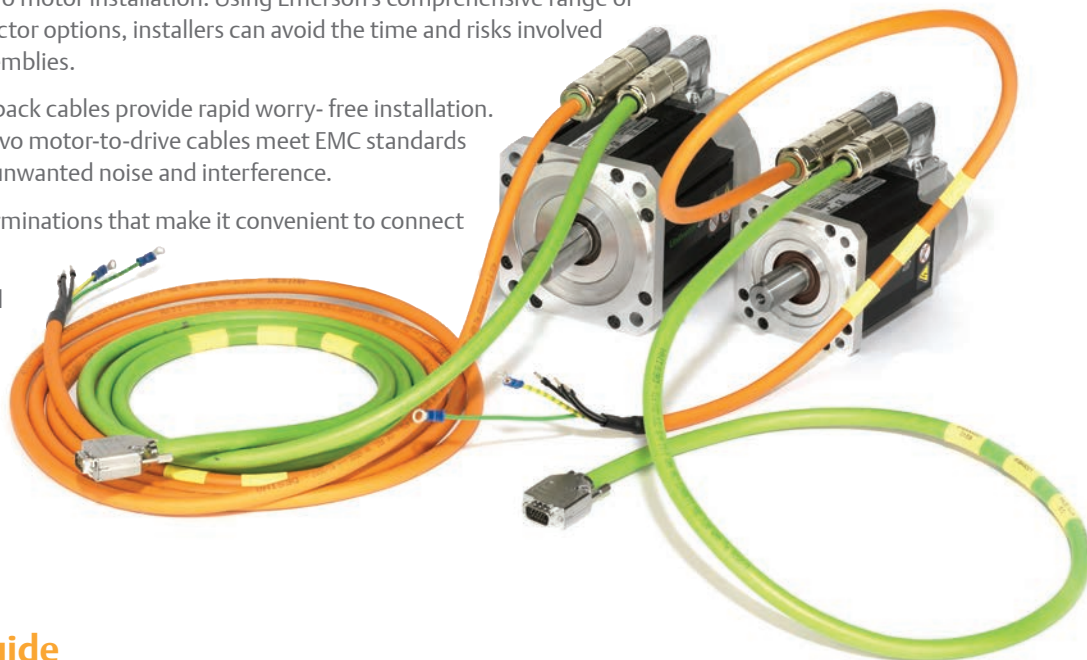

Cable Selection Guide

Cable Type	Servo Motors			Servo Drives				
	Unimotor hd/fm	NT	XV	Digitax ST	Unidrive M	Unidrive SP	Epsilon EP	MDS
★MS	✓	✓		✓	✓	✓	✓	✓
★MB	✓	✓		✓	✓	✓	✓	✓
CM		✓					✓	✓
XT			✓	✓	✓	✓	✓	
XCM			✓ (130 frame)	✓	✓	✓	✓	
Feedback								
★SI	✓	✓		✓	✓	✓	✓	✓
★SR	✓			✓	✓	✓		
★SS	✓	✓		✓	✓	✓		
UF		✓		✓	✓	✓	✓	
CF		✓						✓
XU			✓	✓	✓	✓	✓	
XCF			✓	✓	✓	✓	✓	

NOTE:

★Flexible (Flex duty) rated cables

Cable Selection – Unimotor hd, Unimotor fm

Power Cables

MS	B	A		A	A	0150	
Cable Type	Jacket	Phase and Ground Conductor Size*		Connection Details – Drive End	Connection Details – Motor End	Cable Length	
MS = Power	B = PUR	MS/MB conductors	MB Brake wires	A = Unidrive M size 3-4-5, Unidrive SP size 0-1-2, Digitax ST	A = Size 1 power connector (cable 1-4 mm ²)	Min = 0010 (1 m)	
MB = Power (with brake)				075 - 142 Unimotor fm	075 - 115 Unimotor Fan Blown	Max = 1000 (100 m)	
A = 1.0 mm ² 10 A		0.5 mm ²	B = Unidrive M size 6, Unidrive SP size 3	075 - 142 Unimotor hd (all except table below)	Standard lengths	0050 = 5 meters	
B = 2.5 mm ² 22 A		0.5 mm ²	C = Unidrive M size 7	B = Size 1.5 power connector (cable above 4 mm ²)	0100 = 10 meters	0150 = 15 meters	
C = 4.0 mm ² 30 A		1.0 mm ²	D = Unidrive M size 8-10	142 Unimotor fm/hd (see table below)	0200 = 20 meters	0250 = 25 meters	
D = 6.0 mm ² 39 A		1.0 mm ²	G = Unidrive SP size 4-5-6	190 - 250 Unimotor fm	0300 = 30 meters		
E = 10.0 mm ² 53 A		1.0 mm ²	K = Epsilon EP/MDS	142 - 190 Unimotor Fan Blown			
F = 16.0 mm ² 70 A	1.0 mm ²		190 Unimotor hd				
			P = 6 way male plug for Extension cable				
			X = Cut end (no connectors)				
				C = Size 1.5 power connector (cable 6-16 mm ²)			
				D = 075-250 Unimotor fm hybrid box prepped flying leads			
				X = Cut end (no connectors)			
				142 Unimotor fm/hd Frames using cable order code "B" power connector			
				Motor	Frame	RPM	Order Code
				142ED	C, D	2000	B
				142ED 142E3	E	2000	B
				142ED	C	3000	B
				142ED 142E3	D, E	3000	B
				142UD	D, E	3000	B
				142E3	C, D, E	4000	B
				142U3	D, E	4000	B

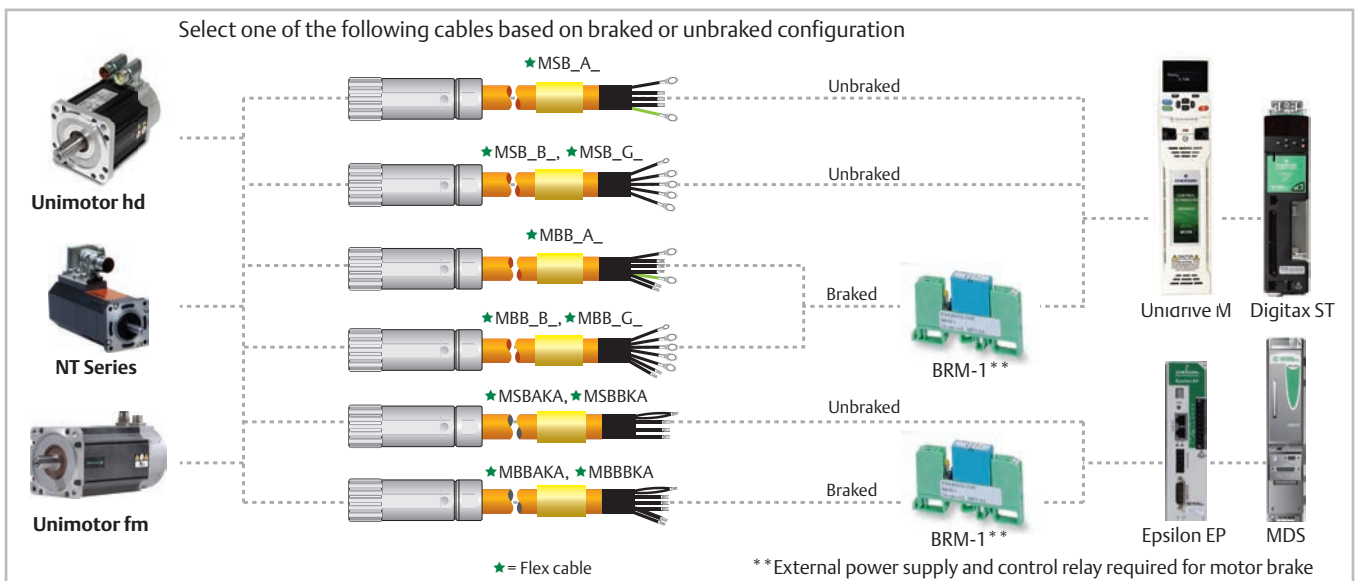

Cable Selection — Unimotor hd, Unimotor fm, NT (-ExNS)

Motor Power Cables

Part Number	Order Code for Length	Description - Power Cable no brake leads
MSBAAA	0030 = 3 meters 0050 = 5 meters 0100 = 10 meters 0150 = 15 meters 0200 = 20 meters 0250 = 25 meters 0300 = 30 meters	10A (1 mm ²) Motor Power Cable, flying leads with ultrasonic welds on drive end (Unidrive M size 3-5 and Digitax ST). Size 1 motor power connector.
MSBBAA		22A (2.5 mm ²) Motor Power Cable, flying leads with ultrasonic welds on drive end (Unidrive M size 3-5 and Digitax ST). Size 1 motor power connector.
MSBCAA		30A (4 mm ²) Motor Power Cable, flying leads with ultrasonic welds on drive end (Unidrive M size 3-5 and Digitax ST). Size 1 motor power connector.
MSBCBA		30A (4 mm ²) Motor Power Cable, M6 ring terminals on drive end (Unidrive M size 6). Size 1 motor power connector.
MSBCAB		30A (4 mm ²) Motor Power Cable, flying leads on drive end (Unidrive M size 3-5 and Digitax ST). Size 1.5 motor power connector.
MSBDBC		39A (6 mm ²) Motor Power Cable, M6 ring terminals drive end (Unidrive M size 6). Size 1.5 motor power connector.
MSBEBC		53A (10 mm ²) Motor Power Cable, M6 ring terminals on drive end (Unidrive M size 6). Size 1.5 motor power connector.
MSBAKA		10A (1 mm ²) Motor Power Cable, flying leads with ultrasonic welds on drive end (Epsilon EP202-209). Size 1 motor power connector.
MSBBKA		22A (2.5 mm ²) Motor Power Cable, flying leads with ultrasonic welds on drive end (Epsilon EP216). Size 1 motor power connector.
Part Number		Order Code for Length
MBBAAA	0030 = 3 meters 0050 = 5 meters 0100 = 10 meters 0150 = 15 meters 0200 = 20 meters 0250 = 25 meters 0300 = 30 meters	10A (1 mm ²) Motor Power Cable and brake leads, flying leads with ultrasonic welds on drive end (Unidrive M size 3-5 and Digitax ST). Size 1 motor power connector.
MBBBAA		22A (2.5 mm ²) Motor Power Cable and brake leads, flying leads with ultrasonic welds on drive end (Unidrive M size 3-5 and Digitax ST). Size 1 motor power connector.
MBBCAA		30A (4 mm ²) Motor Power Cable and brake leads, flying leads with ultrasonic welds on drive end (Unidrive M size 3-5 and Digitax ST) Size 1 motor power connector.
MBBCBA		30A (4 mm ²) Motor Power Cable and brake leads, M6 ring terminals on drive end (Unidrive M size 6). Size 1 motor power connector.
MBBCAB		30A (4 mm ²) Motor Power Cable and brake leads, flying leads on drive end (Unidrive M size 3-5 and Digitax ST). Size 1.5 motor power connector.
MBBDBC		39A (6 mm ²) Motor Power Cable and brake leads, M6 ring terminals drive end (Unidrive M size 6). Size 1.5 motor power connector.
MBBEBC		53A (10 mm ²) Motor Power Cable and brake leads, M6 ring terminals on drive end (Unidrive M size 6). Size 1.5 motor power connector.
MBBAKA		10A (1 mm ²) Motor Power Cable and brake leads, flying leads with ultrasonic welds on drive end (Epsilon EP202-209). Size 1 motor power connector.
MBBBKA		22A (2.5 mm ²) Motor Power Cable and brake leads, flying leads with ultrasonic welds on drive end (Epsilon EP216). Size 1 motor power connector.
Part Number		Standard Lengths (m)
Undressed cable is available using cut-end order code option (example MBBAXX)		

NOTE: Custom lengths available in 1-meter increments

Cable Selection – Unimotor hd, Unimotor fm, NT (-ExNS)

Motor Power Extension Cables: Unidrive M/Unidrive SP/Digitax ST/Epsilon EP

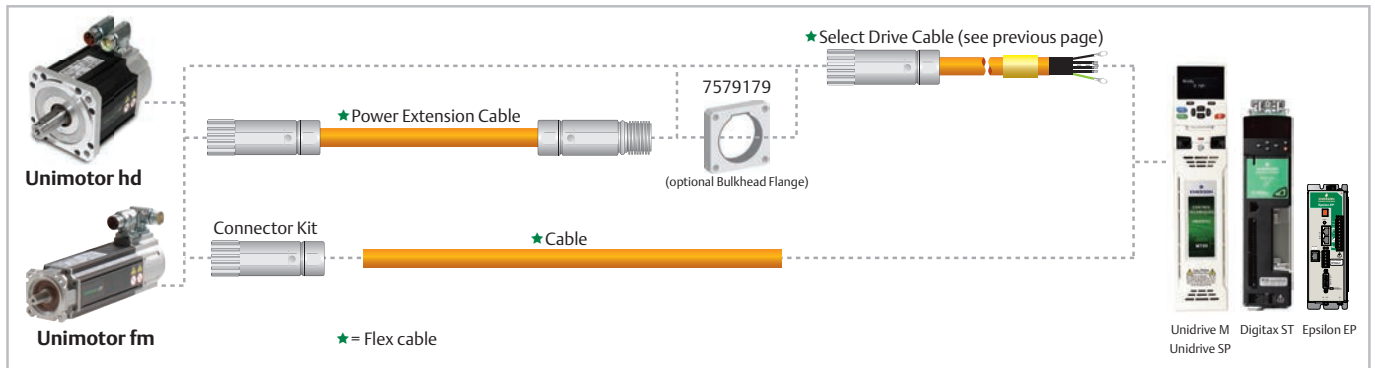

Part Number	Standard Lengths (m)	Description – Power Extension Cable*
★MSB_PA	0030 = 3 meters 0050 = 5 meters	Motor power extension, flex rated, 055 to 115 frames and NT (-EONS); 142 frame B connector type (size 1.0 power connector)
★MBB_PA	0100 = 10 meters 0150 = 15 meters	Motor power extension w/brake leads, flex rated, 055 to 115 frames and NT (-EBNS) (size 1.0 power connector)
★MSB_PB	0200 = 20 meters 0250 = 25 meters	Motor power, extension flex rated, 190 frame; 142 frame J connector type (size 1.5 power connector)
★MBB_PB	0300 = 30 meters	Motor power extension w/brake leads, flex rated, 190 frame; 142 frame J connector type (size 1.5 power connector)

★ Flex duty

NOTES:

*Custom lengths available in 1 m increments
Fill in blank with appropriate conductor size

Part Number	Standard Lengths (m)	Description – Connector Kits (includes brake pins)
IM/0039/KI	–	Power connector kit, female 055-142 frame (30 A); for use with motor connector order code B
IM/0044/KI	–	Power connector kit, female 142, 190 frame (39 A); for use with motor connector order code J
IM/0053/KI	–	Power connector kit, female 190 frame up to (53 A); for use with motor connector order code J
IM/0054/KI	–	Power connector kit, female 190 frame up to (70 A); for use with motor connector order code J
7579179	–	Bulkhead flange kit for power connector size 1; for use with motor connector order code B

Conductor Size	Drive
A = 1.0 mm ² (10 A)	All Digitax ST, Epsilon EP202, EP204, EP06, EP209, MD-404, MD-407
B = 2.5 mm ² (22 A)	Unidrive M, Unidrive SP up to 22 A, MD-410, MD-420
C = 4.0 mm ² (30 A)	Unidrive M, Unidrive SP up to 30 A
D = 6.0 mm ² (39 A)	Unidrive M, Unidrive SP up to 39 A, MD-434
E = 10.0 mm ² (53 A)	Unidrive M, Unidrive SP up to 53 A
F = 16.0 mm ² (70 A)	Unidrive M, Unidrive SP up to 70 A

Cable Selection — Unimotor hd, Unimotor fm

Feedback Cable Options: Unidrive M/Unidrive SP/Digitax ST/Epsilon EP

Incremental Encoder and EnDat Absolute

SI	B	A	A	A	0150
Cable Type	Jacket	Cable Construction	Connection Details — Drive End	Connection Details — Motor End	Cable Length
SI	B	A	A = 15 pin High density D-sub B = Flying leads E = 26 pin D-sub (MDS drive) P = Extension cable plug X = Cut end (No Connector)	A = Unimotor (17 pin) X = Cut end (No Connector)	0030 = 3 meters 0050 = 5 meters 0100 = 10 meters 0150 = 15 meters 0200 = 20 meters 0250 = 25 meters 0300 = 30 meters

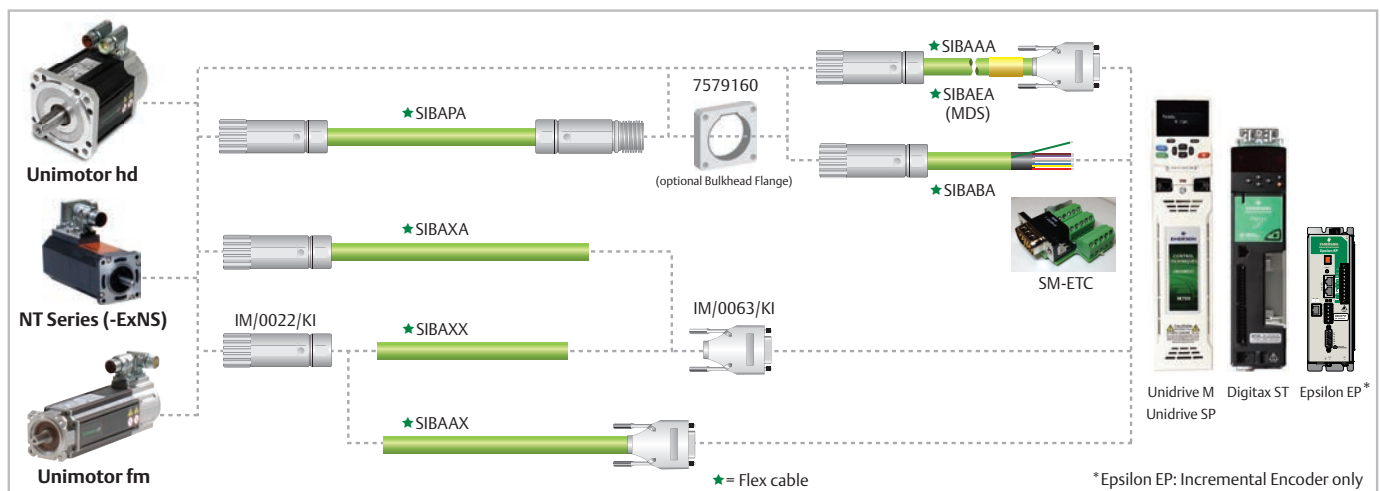

Part Number	Order Code for Length	Description – Unidrive M/Unidrive SP/Digitax ST/Epsilon EP Incremental encoder and EnDat cables
SIBAAA		incremental or Heidenhain EnDat, encoder feedback cable, connectors on drive and motor ends, custom length in 1 meter increments
SIBABA	0030 = 3 meters 0050 = 5 meters 0100 = 10 meters 0150 = 15 meters 0200 = 20 meters 0250 = 25 meters 0300 = 30 meters	incremental or Heidenhain EnDat, encoder feedback cable, prepped flying leads on drive end, connector on motor end, custom length in 1 meter increments.
SIBAXA		incremental or Heidenhain EnDat, encoder feedback cable, cut on drive end, connector motor end, custom length in 1 meter increments.
SIBAXX		incremental or Heidenhain EnDat, encoder feedback cable, connector drive end, cut on motor end, custom length in 1 meter increments.
SIBAPA		extension cable, incremental or Heidenhain EnDat, encoder feedback cable, custom length in 1 meter increments
SIBAXX	1 meter Increments	incremental or Heidenhain EnDat, encoder feedback cable, cut on both ends
Part Number	Description – Unidrive M/Unidrive SP/Digitax ST Feedback Cable connectors	
IM/0022/KI	Feedback connector kit, Incremental and Heidenhain encoders	
IM/0023/KI	Feedback connector kit, Sick Stegmann HIPERFACE and sincos encoders	
IM/0063/KI	Feedback connector kit, drive end, 15-pin	
7579160	Optional feedback connector flange kit for bulkhead	
Part Number	Description – Unidrive M/Unidrive SP/Digitax ST Feedback connector Breakout PCB	
SM-ETC	DP 15 to terminal break out board for	

Cable Selection – Unimotor hd, Unimotor fm

Feedback Cable Options: Motor to Unidrive M/Unidrive SP/Digitax ST

Resolver

SR	B	B	A	B	0150
Cable Type	Jacket	Cable Construction	Connection Details – Drive End	Connection Details – Motor End	Cable Length
SR	B	B	A = 15 pin High density D-sub B = Flying leads P = Extension cable plug X = Cut end (No Connector)	B = Unimotor (12 pin) X = Cut end (No Connector)	0030 = 3 meters 0050 = 5 meters 0100 = 10 meters 0150 = 15 meters 0200 = 20 meters 0250 = 25 meters 0300 = 30 meters

Part Number	Order Code for Length	Description – Unidrive M/Unidrive SP/Digitax SST resolver cables
SRBBAB	0030 = 3 meters	Resolver feedback cable, connectors on drive and motor ends (Digitax ST/Unidrive SP with SM-Resolver)
SRBBBB	0050 = 5 meters	Resolver feedback cable, prepped flying leads on drive end, connector on motor end
SRBBXB	0100 = 10 meters 0150 = 15 meters	Resolver feedback cable, cut on drive end, connector on motor end
SRBBAX	0200 = 20 meters	Resolver feedback cable, connector on drive end, cut on motor end (Digitax ST/Unidrive SP with SM-Resolver)
SRBBPB	0250 = 25 meters 0300 = 30 meters	Extension cable, resolver feedback cable, (Digitax ST/Unidrive SP with SM-Resolver)
SRBBXX	1 meter Increments	Resolver feedback cable, cut on both ends

HIPERFACE Absolute and SinCos

SS	B	C	A	B	0150
Cable Type	Jacket	Cable Construction	Connection Details – Drive End	Connection Details – Motor End	Cable Length
SS	B	C	A = 15 pin High density D-sub B = Flying leads P = Extension cable plug X = Cut end (No Connector)	B = Unimotor (12 pin) X = Cut end (No Connector)	0030 = 3 meters 0050 = 5 meters 0100 = 10 meters 0150 = 15 meters 0200 = 20 meters 0250 = 25 meters 0300 = 30 meters

Part Number	Order Code for Length	Description – Unidrive M/Unidrive SP/Digitax ST HIPERFACE and sincos cables
SSBCBB	0030 = 3 meters 0050 = 5 meters	Sincos, Sick/Stegmann HIPERFACE, encoder feedback cable, prepped flying leads on drive end, connector on motor end
SSBCAB	0100 = 10 meters	Sincos, Sick/Stegmann HIPERFACE, encoder feedback cable, connectors on drive and motor end
SSBCXB	0150 = 15 meters 0200 = 20 meters	Sincos, Sick/Stegmann HIPERFACE, encoder feedback cable, cut on drive end, connector on motor end
SSBCAX	0250 = 25 meters 0300 = 30 meters	Sincos, Sick/Stegmann HIPERFACE, encoder feedback cable, connector on drive end, cut on motor end
SSBCPB		Extension cable, Sincos, Sick/Stegmann HIPERFACE, encoder feedback cable
SSBCXX	1 meter Increments	Sincos, Sick/Stegmann HIPERFACE, encoder feedback cable, cut on both ends

NOTE: Custom length in 1 meter increments

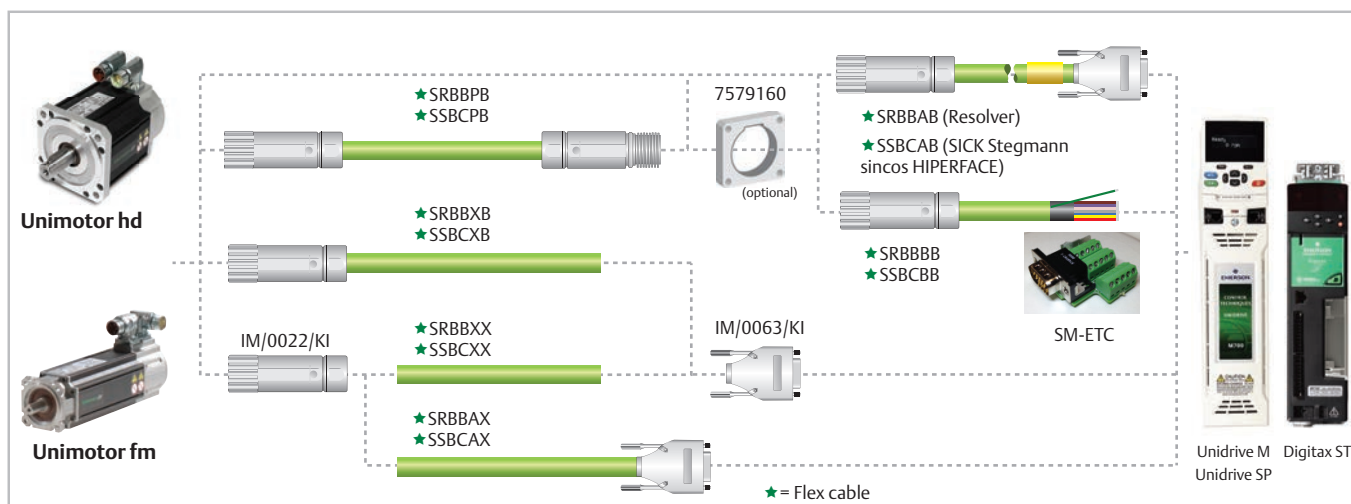

SERVO MOTOR CABLES

Cable Selection — Unimotor hd, Unimotor fm

Power: PUR Basic Cable Diameters (MS/MB)

Cable Code	Phase and Conductor Size (Current Rating Cenlec En60204.1)	Overall Cable Diameter			
		No Brake		Braked	
	(mm ²)	(in)	(mm)	(in)	(mm)
MxBA	A - 1.0 (10 A)	0.311	7.9	0.374	9.5
MxBB	B - 2.5 (22 A)	0.433	11.0	0.472	12.0
MxBC	C - 4.0 (30 A)	0.480	12.2	0.523	13.3
MxBD	D - 6.0 (39 A)	0.768	14.5	0.610	15.5
MxBE	E - 10.0 (53 A)	0.728	18.5	0.740	18.8
MxBF	F - 16.0 (70 A)	0.842	21.4	0.850	21.6

- NOTES:
- Minimum bend radius = 5x dia. fixed, 7.5x dia. dynamic
 - Bending life 5,000,000 cycles
 - Maximum acceleration = 131 ft/s² (40 m/s²)
 - Temperature rating = -22 to 176 °F (-30 to 80 °C)

Feedback: Maximum Cable Lengths

Cable Types	Maximum Cable Length (Meters)		
	Resolver	Sick Stegmann	Heidenhain
SIBA incremental		CA/CR 50 m*	EC/FC 20 m EB/FB 30 m
SRBB Resolver	AR/AE 100 m		
SSBC SinCos		RA/SA 100 m	

* 324 ft (100 m) if +5V tolerance can be maintained at +/-10%

Feedback: PUR Basic Cable Diameters

Cable Code	Overall Cable Diameter	
	(in)	(mm)
SIBA	0.394	10.0
SRBB	0.335	8.5
SSBC	0.350	8.9

- NOTES:
- Minimum bend radius = 5x dia. fixed, 7.5x dia. dynamic
 - Bending life 5,000,000 cycles
 - Maximum acceleration: 131 ft/s² (40 m/s²)
 - Temperature rating = -22 to 176 °F (-30 to 80 °C)

Motor Connector Details

			Incremental Encoder	EnDat Heidenhain SinCos, Absolute Encoders	Resolver	HIPERFACE SICK Stegmann SinCos, Absolute Encoders
Feedback Order Code			(CR, CA, MA, MR)	(EM, FM, EC, FC, EB, FB)	(AR, AE)	(RA, SA)
Common Cable Order Code			SIBAAA		SRBBAB	SSBCAB
Power Pin Functions			Feedback Pin Functions			
Pin	Size 1.0 [with Brake]	Size 1.5 [with Brake]				
1	Phase U (R)	Phase U (R)	Thermistor	Thermistor	Excitation high	REF cos
2	Phase V (S)	Phase V (S)	Thermistor	Thermistor	Excitation low	+ Data
3	Ground	Ground (⊕)		Screen (encoder only)	Cos high	- Data
4	Phase W (T)	Phase W (T)	U		Cos low	+ Cos
5	[Brake]	[Brake (+)]	U/		Sin high	+ Sin
6	[Brake]	[Brake (-)]	V		Sin low	REF sin
7			V/		Thermistor	Thermistor
8			W	+ Clock	Thermistor	Thermistor
9			W/	- Clock		Screen
10			A	+ Cos		0 Volts
11			Z	+ Data		+ Volts
12			Z/	- Data		
13			A/	- Cos		
14			B	+ Sin		
15			B/	- Sin		
16			+ Volts	+ Volts		
17			0 Volts	0 Volts		
Shell	Shield	Shield	Shield	Shield		Shield

Power Plugs

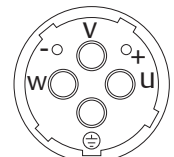

Size 1.5

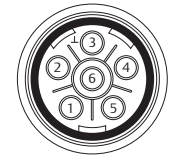

Size 1.0

Feedback Plugs

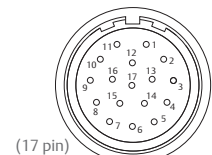

(17 pin)

(Incremental, Heidenhain encoders)

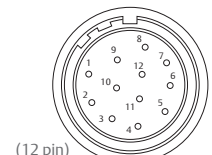

(12 pin)

(Resolver, Sick/Stegmann encoders)

Cable Selection — NT Motors to Drives

Power Cable Options: Unidrive M/Unidrive SP/Digitax ST/Epsilon EP

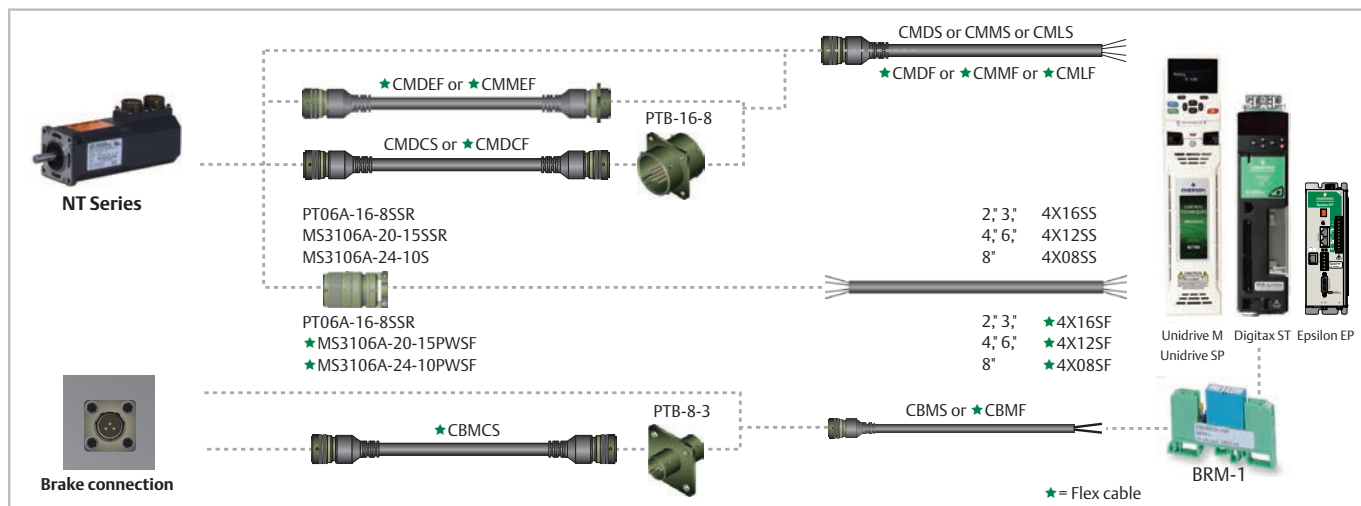

Part Number	Standard Lengths (ft)	Description – Power Cables and Connectors
CMDS	-005, -015, -025, -050, -100	Molded cable, 16 AWG for 2" and 3" motors, connector on motor end, ferrules on drive end; IP65 shielded connector
CMMS	-005, -015, -025, -050, -100	Molded cable, 12 AWG for 4" and 6" motors, connector on motor end, ferrules on drive end; IP65 shielded connector
CMLS	-005, -015, -025, -050, -100	Molded cable, 8 AWG for 8" motors, connector on motor end, ferrules on drive end; IP65 shielded connector
CMDCS	—	Molded cable, connects to bulkhead on one end, motor connector on the other end for 2" and 3" motors
★CMDF	-005, -015, -025	Molded flex cable, connector at motor end for 2" and 3" motors; min. bend radius 5.6"
★CMMF	-005, -015, -025	Molded flex cable, connectors at both ends for 4" and 6" motors; min. bend radius 9.0" flexing, 6" stationary
★CMLF	-005, -015, -025	Molded flex cable, connector at motor end for 8" motors; min. bend radius 9" flexing, 6" for stationary
★CMDEF	-005, -015, -025	Molded flex extension cable, connectors at both ends for 2" and 3" motors; min. bend radius 5.6"
★CMMEF	-005, -015, -025	Molded flex cable, connectors at both ends for 4" and 6" motors; min. bend radius 9.0" flexing, 6" stationary
★CMDCF	—	Flex cable, connects bulkhead on one end, motor on the other for 2" and 3" motors; min. bend radius 5.6"
4X08SS	—	Cable for 8" motors, 4-wire, 8AWG w/shield; 0.480" (12.2 mm) diameter
4X12SS	—	Cable for 4" and 6" motors, 4-wire 12AWG w/shield; 0.440" (11.2 mm) diameter
4X16SS	—	Cable for 2" and 3" motors, 4-wire, 16 AWG w/shield; 0.380" (9.7 mm) diameter
★4X16SF	—	Flex cable for 2" and 3" motors, 4-wire, 16AWG, w/shield; min. bend radius 5.6"
★4X12SF	—	Flex cable for 4" and 6" motors, 4-wire, 12AWG, w/shield; min. bend radius 9.0"
★4X08SF	—	Flex cable for 8" motors, 4-wire, 8AWG, min. bend radius 9.2" for flexing
PT06A-16-8SSR	—	Motor power connector for 2" and 3" NT motors, female, not IP65, not shielded, flex or non-flex cable
★PT06E-16-8SWSF	—	Motor end power cable, female, w/backshell, IP65, IP65 shielded connector for 2" and 3" motors
★PT01E-16-8PWSF	—	Extension (male) mates with motor end of motor cable; IP65, shielded, for 2" and 3" motors
MS3106A-20-15SSR	—	Motor power connector for 4" and 6" NT motors, female, not IP65, not shielded
★MS3106A-20-15WSF	—	4" motor power connector, female, not IP65 shielded
★MS3101A-20-15PWSF	—	Power cable extension plug for 4" motors, male; mates with motor end of motor cable (not shown above)
PTB-16-8	—	Motor bulkhead connector for 2" and 3" motors
Part Number	Standard Lengths (ft)	Description – Brake Cables and Connectors
CBMS	-005, -015, -025, -050, -100	Molded cable, standard duty, connector at motor only
★CBMF	-005, -015, -025, -050, -100	Flex cable, connector at drive, leads at motor; IP65 shielded connector for 2", 3", 4", 6" motors; min. bend radius 3"
★CBMCS	—	Cable to be connected to bulkhead connector on one end and motor connector on the other end
PT06A-8-3SSR	—	Brake connector kit (not shown above)
PTB-8-3	—	Brake bulkhead connector
BRM-1	—	Brake relay module, 24 V, 1 contract, 6 A, DIN rail mounting

NOTE: Custom lengths available in 5 ft increments

Cable Selection — NT Motors to Drives

Feedback Cable Options: Unidrive M/Unidrive SP/Digitax ST/Epsilon EP — Incremental Encoders

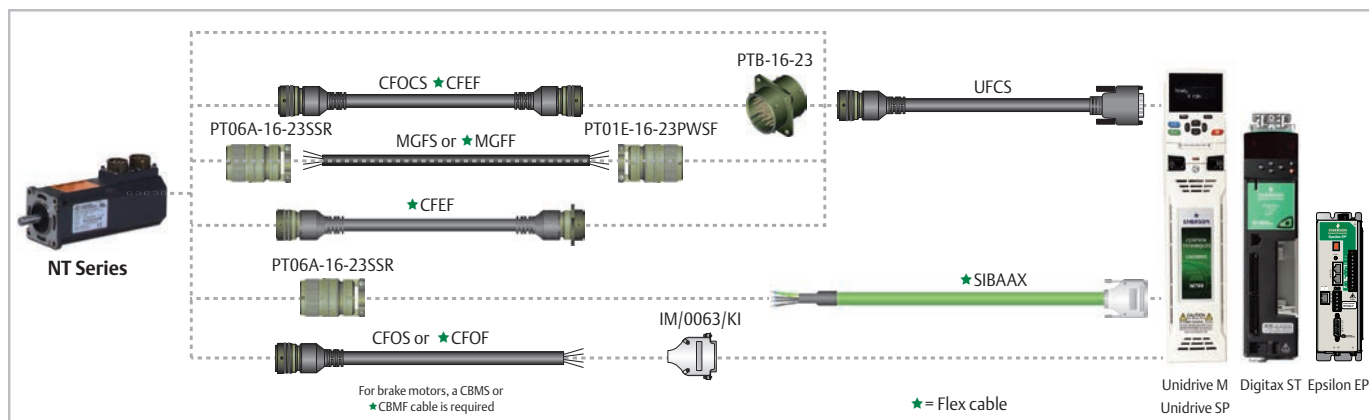

Part Number	Standard Lengths (ft)	Description – Feedback Cables and Connectors
UFCS	-005, -015, -025, -050, -100	Molded cable, connector both ends
MGFS		Standard duty cable for 2" and 3" motors, 8-pair with shield
★MGFF		Flex cable for 2" and 3" motors, 8 pair with shield; min. bend radius 5.6" for flexing, 10 million cycles
CFOCS		Molded extension cable, connects to bulkhead on one end, motor connector on the other end
★CFCF	-005, -015, -025, -050, -100	Flex duty feedback cable for use with PTB-16-23 bulkhead connector, min. bend radius: 5.6" flexing, 10 million cycles
★CFEF	-005, -015, -025, -050, -100	Flex extension cable for encoder feedback motors w/circ. connectors both ends; min. bend radius: 5.6" flexing, 10 million cycles
CFOF	-005, -015, -025, -050, -100	Flex motor feedback cable, connector at motor end only; min. bend radius 5.6" for flexing, 10 million cycles
CFOF	-005, -015, -025, -050, -100	Motor feedback cable, connector at motor only
PT06A-16-23SSR	—	Female connector for motor feedback cable, not IP65, not shielded
PT01E-16-23PWSF	—	Male connector for standard motor feedback cable, use at enclosure end with PTB-16-23, IP65 shielded connector
PTB-16-23	—	Through-the-wall bulkhead connector for feedback cables
★SIBAAX	Lengths are in meters	Incremental feedback cable, connector drive end, high density 15-pin
IM/0063/KI	—	High density 15-pin connector, motor feedback connector on SP,DST, EP
Part Number	Standard Lengths (ft)	Description – Encoder Breakout Board
STI-ENC	—	Epsilon EP drive encoder breakout PCB, push-in terminals
SM-ECT	—	Unidrive M/Unidrive SP/Digitax ST drives encoder breakout PCB, screw terminals

NOTE: Custom lengths available in 5 ft increments

Cable Selection — XV Motors to Drives

XV Motor Cables

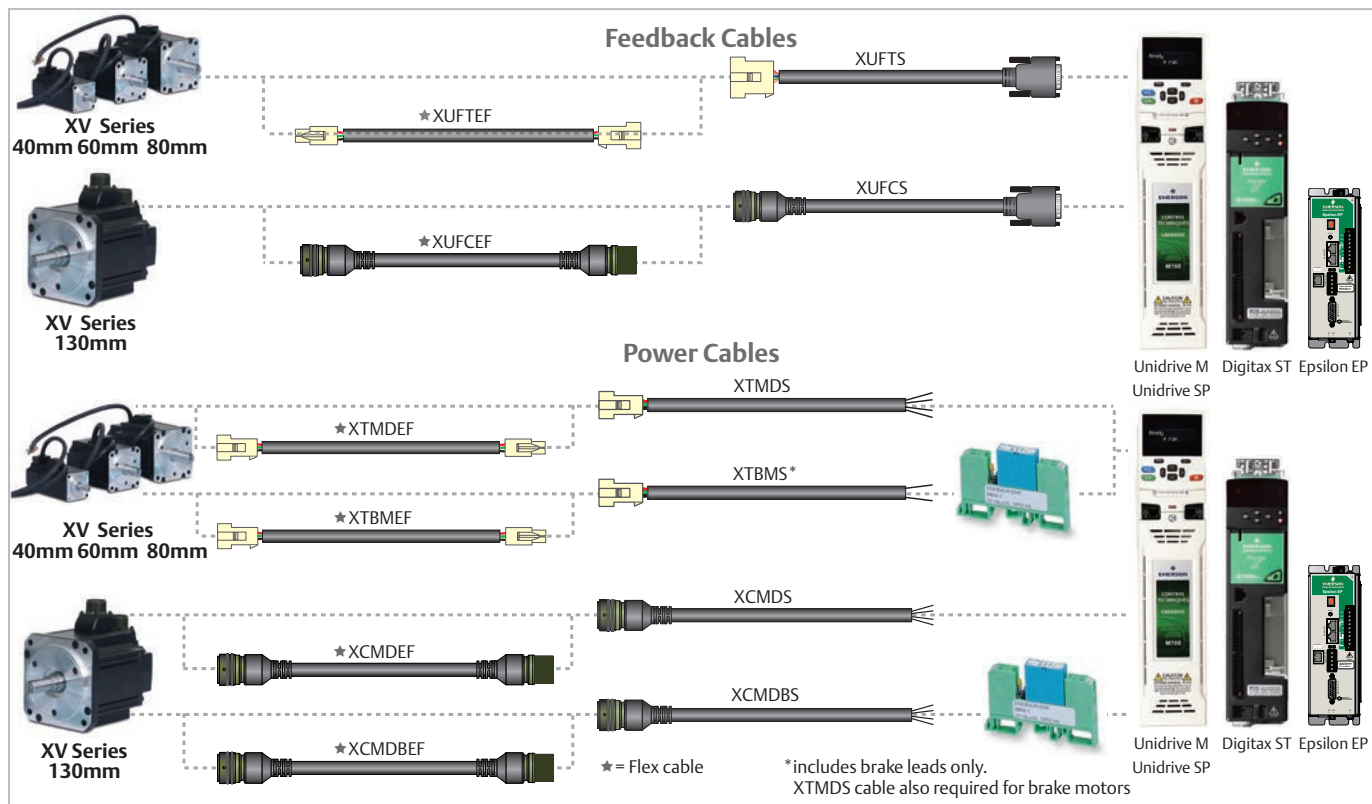

Part Number	Standard Lengths (ft)	Description – Feedback Cables and Connectors
XUFCS	-005, -015, -025, -050, -100	XV Motor feedback cable.
XUFTS	-005, -015, -025, -050, -100	XV 40, 60, 80 mm motor to DSUB connector on drive end; 15-pin, high density socket.
XUFTEF	-005, -015, -025, -050	Flex extension feedback cable for XV 40, 60, 80 mm motor frames, connectors on both ends; bend radius: 5.6" flexing
XUFCEF	-005, -015, -025, -050	Flex extension feedback cable for XV 130 mm motor frames, connectors on both ends; bend radius: 5.6" flexing
Part Number	Standard Lengths (ft)	Description – Power Cables
XCMDS	-005, -015, -025	Motor power cable
XTMDS	-005, -015, -025, -050, -100	Motor power cable
Part Number	Standard Lengths (ft)	Description – Power (Flex) Cables
XCMDEF	-005, -015, -025	Flex motor power cable extension. For use with XCMDS; min. bend radius 5.6"
XTMDEF	-005, -015, -025	Flex motor power cable extension. For use with XTMD5; min. bend radius 5.6"
XTBMEF	-005, -015, -025, -050	Flex duty brake cable for XV 40, 60, 80 mm motor frames; TBNS male connector to TBNS female connector; designed as extension of XCMDS cable
XCMD5S	-005, -015, -025, -050	Flex duty brake cable for XV 40, 60, 80 mm motor frames. TBNS male connector to TBNS female connector; designed as extension of XCMDS cable
Part Number	Standard Lengths (ft)	Description – Brake Cables
XTBMS	-005, -015, -025, -050, -100	Motor brake cable, standard duty, connector at motor only
Part Number	Standard Lengths (ft)	Description – Brake (Flex) Cable and Connectors
XCMDBEF	-005, -015, -025	Flex motor brake cable extension for use with XCMD5S; min. bend radius 5.6"

Fan Kits

Unimotor **fm** and **hd** motors (frame sizes 075 to 250) can be field fitted with a cooling fan. These fan kits are intended for use in applications that operate near the thermal limit of the motor. Each Unimotor is thermally protected with an internal winding thermistor. If the motor experiences a thermal trip condition and is found to be operating near the thermal limit, a fan kit may help provide continuous operation during times of high continuous torque output. The motor thermal protection should never be defeated or bypassed as this could cause permanent damage to the motor.

Fan kits are IP20 and include mounting hardware. A terminal box mounted on the top rear of the fan shroud allows connection to the 230 V fan leads.



FAN KITS

Fan Kits

Part Number	Description
075FB21	075 Unimotor fm Motor Fan Box
095FB21	095 Unimotor fm Motor Fan Box
115FB21	115 Unimotor fm and Unimotor hd Motor Fan Box
142FB21	142 Unimotor fm and Unimotor hd Motor Fan Box
190FB21	190 Unimotor fm and Unimotor hd Motor Fan Box
250FB21	250 Unimotor fm Motor Fan Box

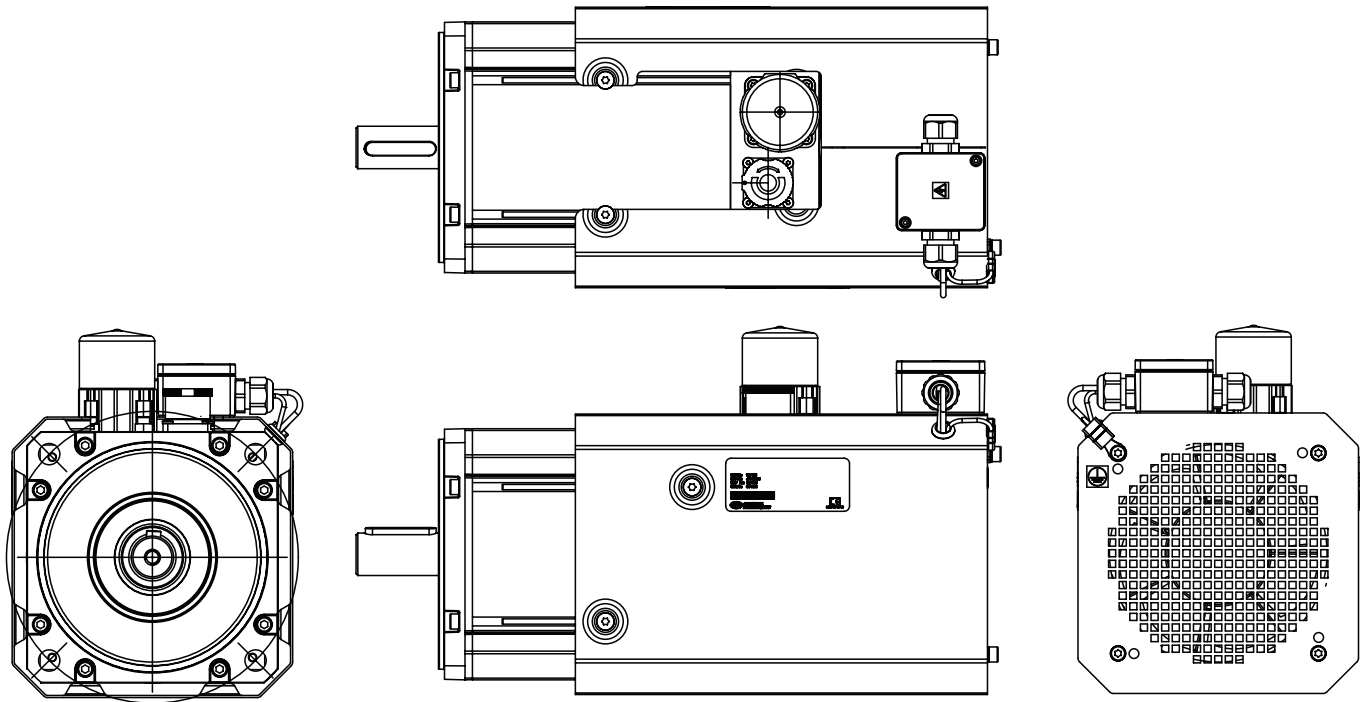

Control Techniques™

Leroy-Somer™

www.emersonindustrial.com/automation

Connect with us at:

twitter.com/ctandls

facebook.com/ctandls

youtube.com/controltechniquesandleroyssomer

theautomationengineer.com (blog)



© Emerson 2015. The information contained in this brochure is for guidance only and does not form part of any contract. The accuracy cannot be guaranteed as Emerson have an ongoing process of development and reserve the right to change the specification of their products without notice.

Control Techniques Limited. Registered Office: The Gro, Newtown, Powys SY16 3BE. Registered in England and Wales. Company Reg. No. 01236886.

Moteurs Leroy-Somer SAS. Headquarters: Bd Marcellin Leroy, CS 10015, 16915 Angoulême Cedex 9, France. Share Capital: 65 800 512 €, RCS Angoulême 338 567 258.