



Shown with optional pressure gauge

Compact, Convenient Size

Dependable Electrical to Pneumatic Conversion

All Necessary Mounting Brackets and Hardware Included

Montalvo Accessories

MPC-4ce I/P Converter and MAF-3 Air Filter

The Montalvo MPC-4ce electro-pneumatic converter provides accurate, dependable conversion of a DC current signal into a proportional pneumatic output. Operating on a 4 to 20 milliamp input, no additional AC or DC power is required. The MPC-4ce has a high flow rate, providing the rapid response required for accurate control of a dancer or load cell tension control system. To simplify installation, "quick-disconnect" fittings are used for the pneumatic piping. Electrical connections are made to a standard DIN connector. The MPC-4ce is supplied with brackets for wall, panel or DIN rail mounting.

Dimensions - MPC-4ce

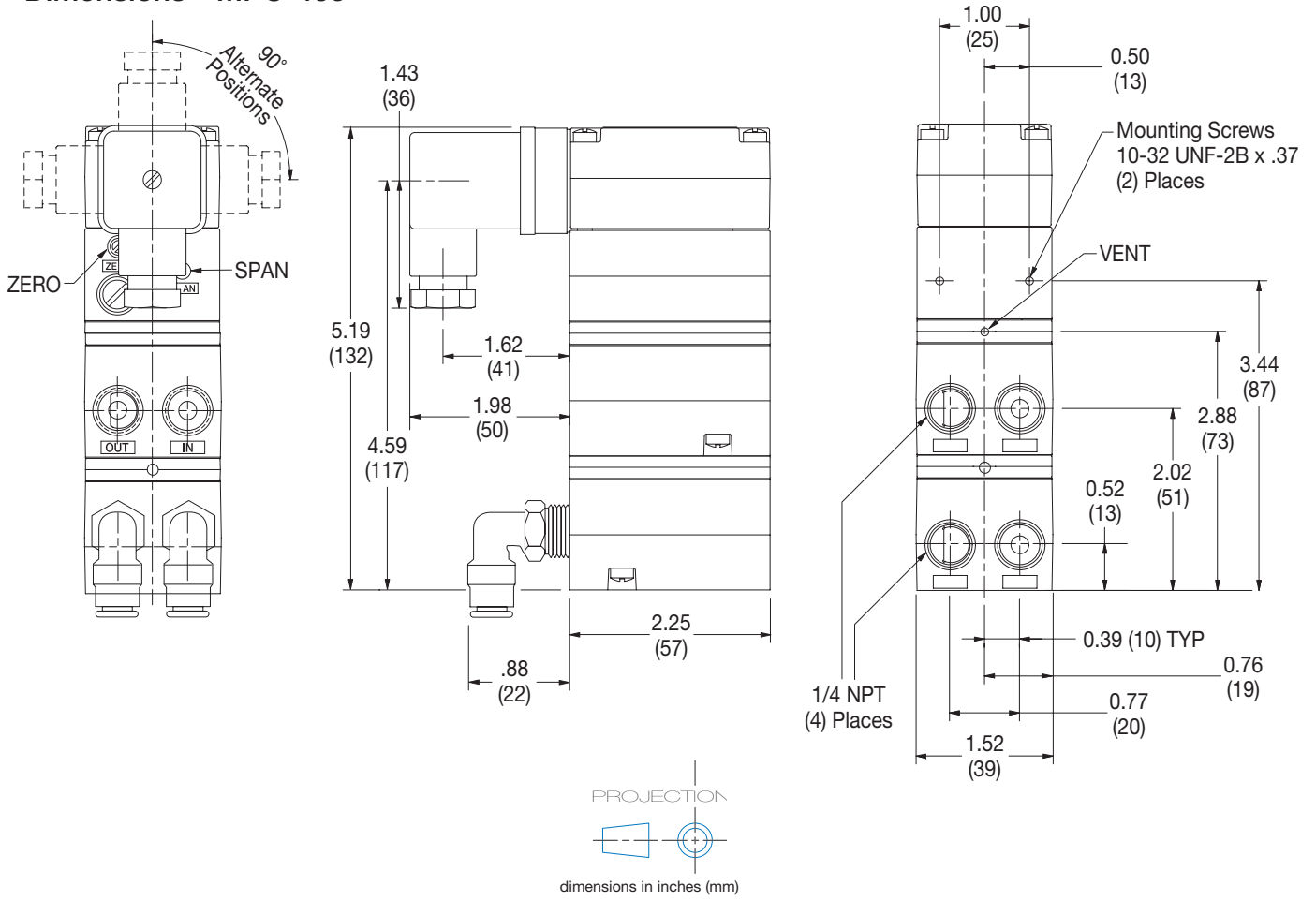

Dimensions - MAF-3

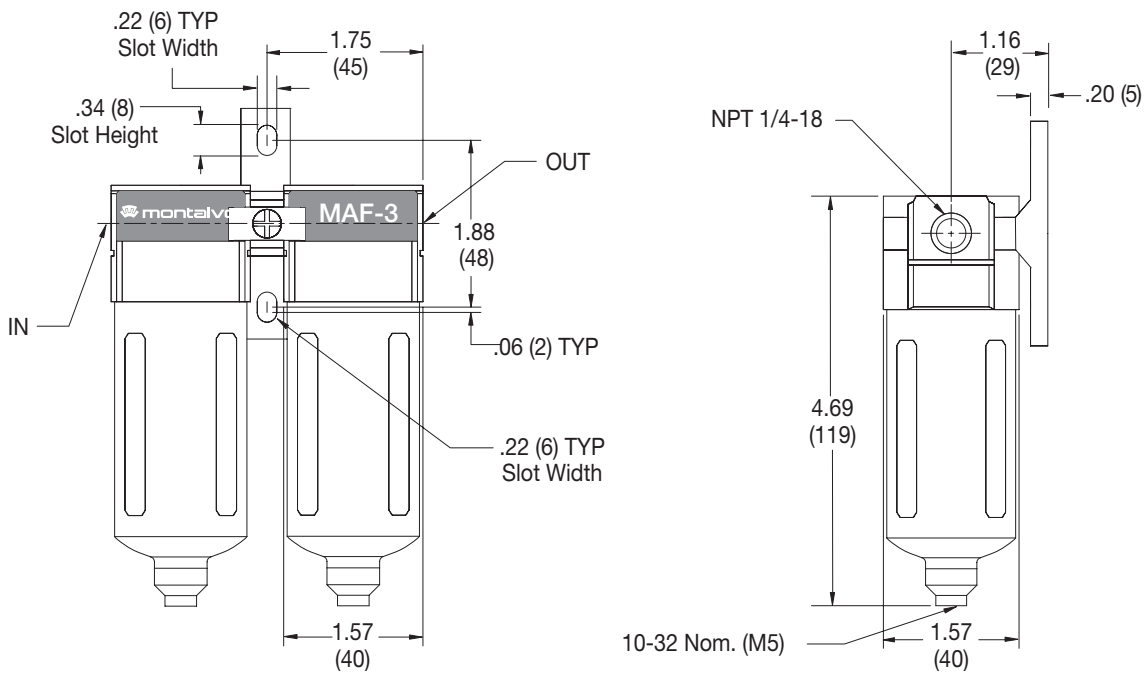

Installation - MPC-4ce

Air Output

Connect to the output with 1/4" O.D. nylon or polyethylene tubing. For maximum performance, mount the MPC-4ce as close as possible to the brake or clutch. Restrictions such as valves or fittings or large volume requirements may increase the response time of the system.

Mounting

The MPC-4ce is supplied with both wall and DIN rail mounting brackets. The wall mounting bracket can be mounted either vertically, as shown below, or horizontally. Breakaway tabs on the mounting plate may be removed to reduce the overall size. The universal DIN rail mounting bracket allows the MPC-4ce to be mounted on a user-supplied DIN rail EN-50022, EN-50035 or EN-50045.

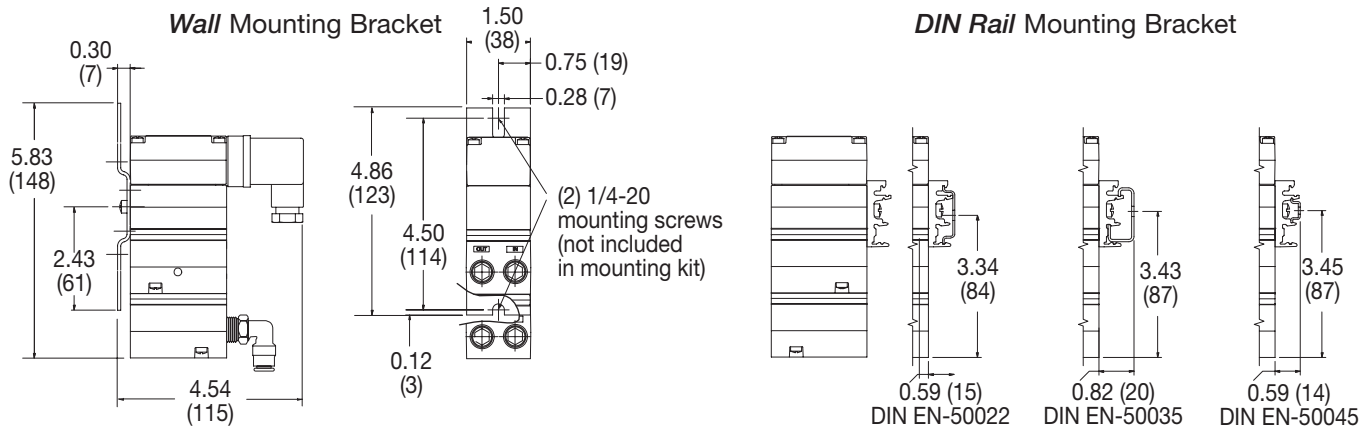

Calibration

The MPC-4ce is calibrated at the factory for a 0 to 75 psi output when the converter is mounted as shown above.

IMPORTANT NOTE - For other mounting positions or different output ranges, use the following procedure:

1. Apply the minimum input signal and adjust the zero screw for an output of 0 psi. Turn the screw clockwise to increase pressure and counterclockwise to decrease pressure.
2. Apply the maximum input signal and adjust the span screw for 75 psi or the required output pressure. Turn the screw clockwise to increase pressure and counterclockwise to decrease pressure.
3. Repeat steps 1 and 2 until the desired output range is obtained.

Installation - MAF-3

Mounting

1. The mist separator should be installed vertically.
2. Flush piping before installation.
3. If a dryer is used, install the mist separator downstream of the dryer.
4. Polycarbonate bowls may be damaged and possibly fail if exposed to synthetic oils, thinner solvents, trichlorethylene kerosene and other aromatic hydrocarbons. If used in above atmosphere a metal bowl is recommended.

Maintenance

1. Filter element should be changed after 1 year or when a pressure drop of 15 psi (1kgf/cm²) is reached.

Replacement filter elements are sold separately through Montalvo:

Montalvo part # 20000157 (5 micron water filter)

Montalvo part # 20000158 (.3 micron oil separating filter)

Auto Drain

1. Drain line should be a soft nylon tube with a 5/16" (8mm) O.D. or more and should be less than 16.5 feet (5m) long. Be sure not to have any upward turns in the drain line which could prevent drainage.
2. Not suitable for flow below 3.5 SCFM (100 Nl/min).
3. Operating pressure is more than 15 psi (1 kgf/cm²).

Air Supply

The air supply must be clean, dry and free of oil. For reliable operation, instrument quality air per ISA Standards D7.3-1981, is required. Use a 5 micron (maximum) filter to remove dirt and liquid in the air line ahead of the I/P converter. The use of an optional Montalvo MAF-3 (5 micron water and 0.3 micron oil separating) filter system is recommended. Failure to do so may degrade the performance and service life of the I/P converter and will void the warranty. Regulate the maximum input air pressure from 80 to 150psi. Connect to the input with 1/4" O.D. nylon or polyethylene tubing.

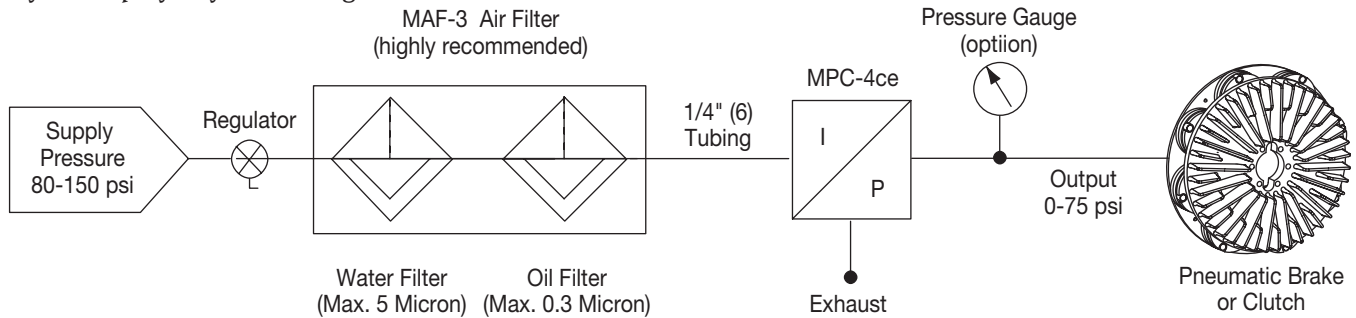

Electrical Supply

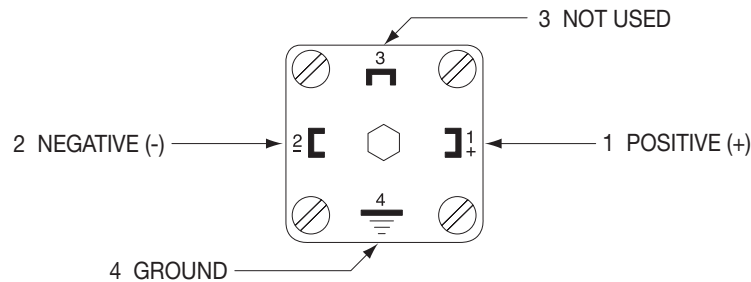

Specifications

MPC-4ce

Input Signal	4 to 20mA
Input Impedance	270Ω
Linearity	± 1% full scale
Hysteresis and Repeatability	< 1% of full scale
Output Range (factory setting)	0 to 75 psi
Supply Pressure	80 to 150 psi
Flow Rate	11 SCFM @ 9 psi output
Temperature Range	20° to +150°F (-30° to +65°C)
Port Size	1/4" NPT
Pressure gauge (OPTIONAL)	0-100 psi (0-7 BAR)

MAF-3

Maximum Pressure	150 psi
Thread Type	1/4" NPT
Bowl Capacity9 oz.
Temperature (amb/med)	40° to 140°F (5° to 60°C)
Air Filter Size	5 micron
Mist Separator Flow Capacity	7 SCFM (200 NI/min.)
Filter Size	0.3 micron
Oil Mist Removal Rate	> 99.9%